

FOREWORD

This service manual has been prepared for the purpose of assisting service personnel in providing efficient and correct service and maintenance on the PFR-KX type injection pump. This manual describes the pump's construction and operation, and includes procedures for disassembly, reassembly and adjustment.

The contents of this manual, including drawings, illustrations and specifications are the latest available at the time of printing. The right is reserved to make changes in specifications and procedures at any time without notice.

A1

Foreword

Fuel injection pump (PFR-KX)



FEATURES

The PFR-KX type fuel injection pump is an improved version of the PFR-KD type pump, and was developed to provide a lighter pump with improved endurance. Its main features are described below.

1. The pump housing has been constructed of a strong aluminum alloy to decrease its weight.
2. The sleeve flange has been constructed of steel to protect the pump itself from high-pressure fuel flow.
3. Because of the pump's improved endurance, it can be used with both swirl chamber type engines and direct injection type engines, which are subjected to extended high-load operation.
4. The PFR-KX can be interchanged with the widely used PFR-KD type pump used with small agricultural engines and general purpose engines.
5. In addition to use with one, three and four cylinder engines, the PFR-KX type pump can now, in response to the demands of small-type diesel engines, also be used with two, five and six cylinder engines.



Principal specifications

Number of cylinders	1, 2, 3, 4, 5, 6
Applicable plunger diameter (\emptyset mm)	5.0, 5.5, 6.0, 6.5, 7.0, 7.5
Standard retraction quantity of delivery valve (mm^3)	20, 25, 30, 35
Applicable injection quantity (mm^3/st)	Approx. 5 to 70
Plunger stroke (mm)	7.0
Control rack travel (mm)	16.0
Maximum allowable speed (r.p.m) (using a standard Diesel Kiki cam)	2000 Refer to Fig. 1
Maximum allowable in-pipe pressure (kg/cm^2)	550
Recommended oil	Light oil, SAE 313 a
Pump weight (kg)	Approx. 0,5 - 2.6

A3

Features

Fuel injection pump (PFR-KX)



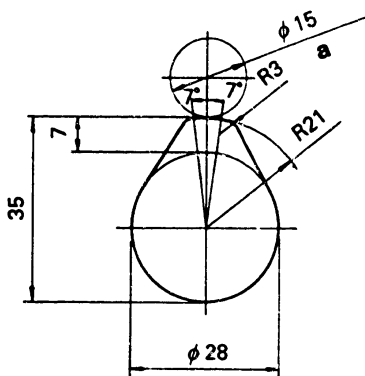

Fig. 1

a = Roller

A4

Features

Fuel injection pump (PFR-KX)

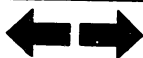

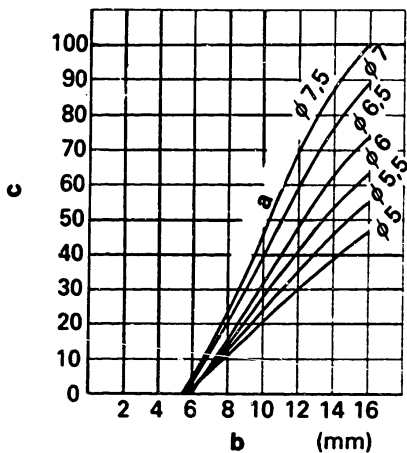

Fig. 2 Injection quantity characteristics

a = Plunger diameter

b = Control rack travel

c = Injection quantity (mm^3/st)

Specifications

Plunger helix : 12 mm

Retraction volume : $35 \text{ mm}^3/\text{st}$

Cam lift : 7 mm



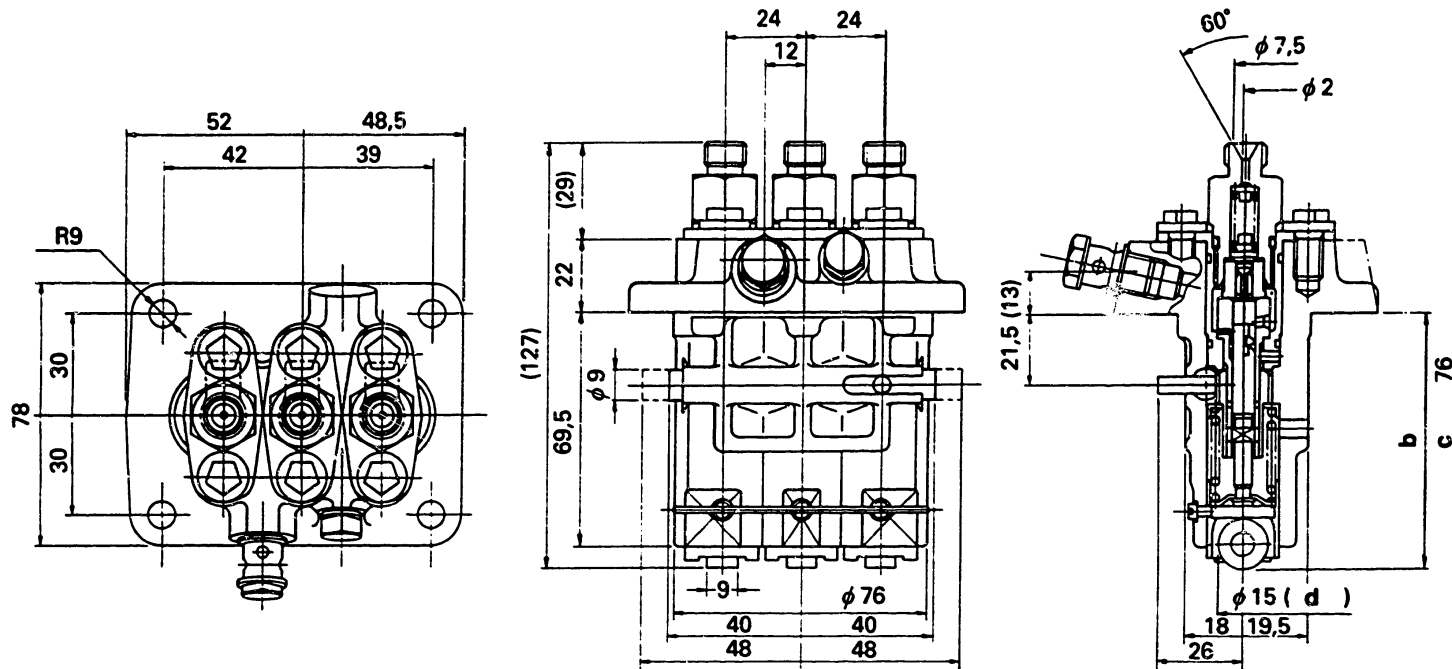

A

B

a : mm

Fig. 3 Dimensions

A = Top view
B = Side view

a = Unit
b = Suggested mounting
c = Dimension
d = Roller

A6

Features

Fuel injection pump (PFR-KX)



A7

Features

Fuel injection pump (PFR-KX)



FUEL SYSTEM

The fuel system for a PFR type injection pump is shown in Figure 4.

The system consists of the injection pump, the fuel tank, the fuel filter, the nozzle and the nozzle holder, all of which are connected by the high- and low-pressure pipes. The fuel tank is positioned above the injection pump and the fuel filter, and the fuel oil is gravity fed to the filter.

The filtered fuel oil then flows to the injection pump's oil chamber and is delivered to the plunger where it is pressurized. The high-pressure fuel oil is then delivered to the nozzle, through the injection pipe and nozzle holder, and is then injected into the engine's cylinder as a fine spray.



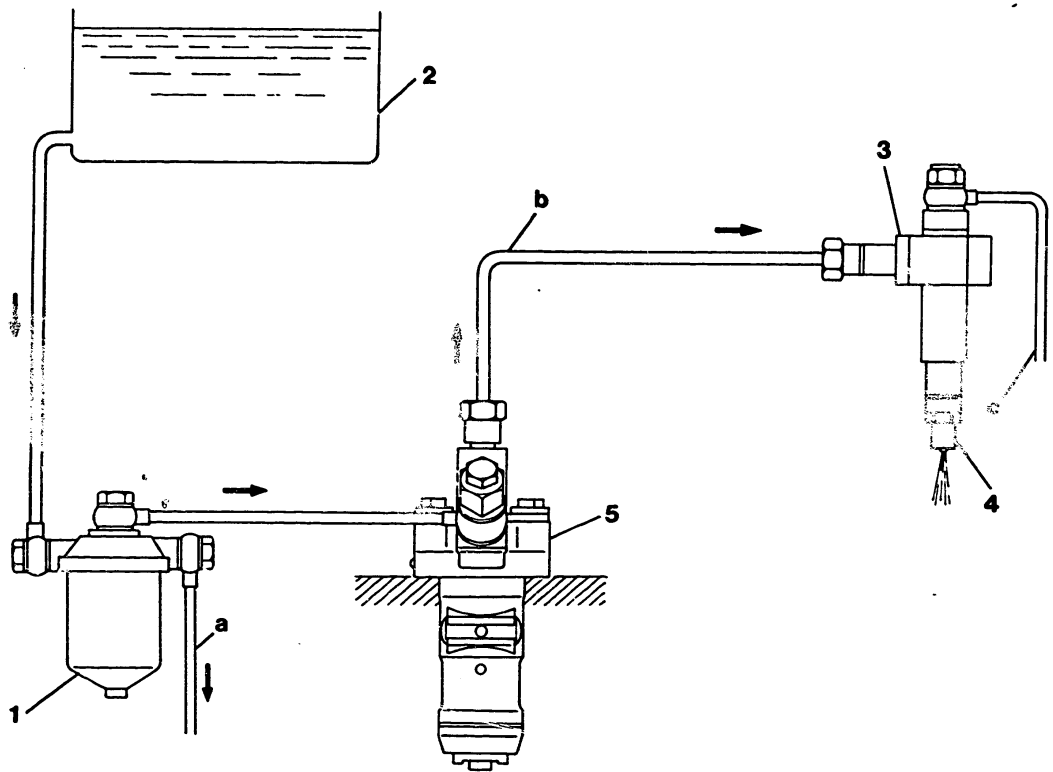

Fig. 4 Fuel system

- 1 = Fuel filter
- 2 = Fuel tank
- 3 = Nozzle holder

- 4 = Nozzle
- 5 = Injection pump

- a = Overflow pipe
- b = Injection pipe
- c = Overflow pipe

A9

Fuel system
Injection pump (PFR-KX)

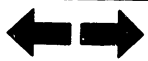

A10

Fuel system
Injection pump (PFR-KX)



CONSTRUCTION AND OPERATION

The PFR injection pump is mounted in the engine's cylinder block. It differs from the PE type injection pump in that it does not have a camshaft, but is driven by the engine's camshaft. Plunger movement is constant, being raised by the tappet and returned by the plunger spring as the engine rotates. The plunger barrel's suction and discharge port opens onto the pump housing's fuel oil chamber, which is always filled with fuel oil.

When the plunger descends, fuel oil is sucked into the plunger barrel, and when the plunger reaches its lowest point, the suction of fuel oil stops.

The plunger then ascends, and when the plunger barrel's suction and discharge port is closed by the plunger, the fuel oil pressure increases. The fuel oil then raises the delivery valve and is delivered through the injection pipe to the nozzle holder. When the fuel oil pressure exceeds the force of the nozzle spring's set force, fuel oil is injected into the engine's combustion chamber in the form of a fine spray.

A11

Construction and operation

Fuel injection pump (PFR-KX)



Construction and operation (continuation)

The plunger further ascends, and when the plunger helix meets the plunger barrel's suction and discharge port, fuel delivery ends (at the same time injection from the nozzle also ends). The delivery valve is then closed by the set force of the delivery valve spring so that fuel oil is no longer delivered, even though the plunger continues to ascend.



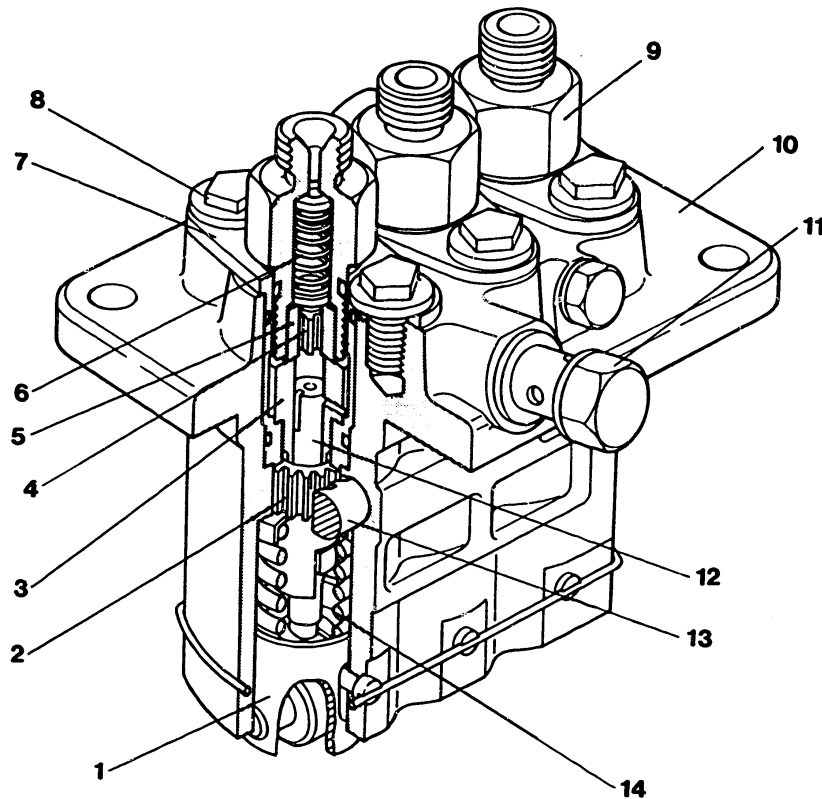

Fig. 5 Fuel injection pump PFR

- 1 = Tappet
- 2 = Control sleeve
- 3 = Plunger barrel
- 4 = Delivery valve
- 5 = Delivery valve seat

- 6 = Delivery valve spring
- 7 = Sleeve flange
- 8 = Five-sided bolt
- 9 = Delivery valve holder
- 10 = Pump housing

- 11 = Eye bolt
- 12 = Plunger
- 13 = Control rack
- 14 = Plunger spring

A13

Construction and operation
Fuel injection pump (PFR-KX)

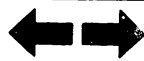

A14

Construction and operation
Fuel injection pump (PFR-KX)

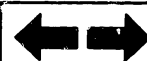

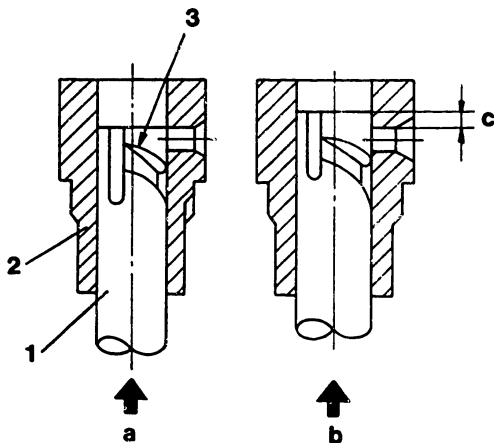

Fig. 6

- 1 = Plunger
- 2 = Plunger barrel
- 3 = Helix

- a = Delivery starts
- b = Delivery ends
- c = Effective stroke

The stroke (effective stroke) from the moment that the plunger barrel's suction and discharge port is closed by the end of the plunger (beginning-of-injection) until the suction and discharge port meets the plunger helix (end-of-injection) can be altered by rotating the plunger. Accordingly, the relationship between injection quantity and effective stroke is proportional.



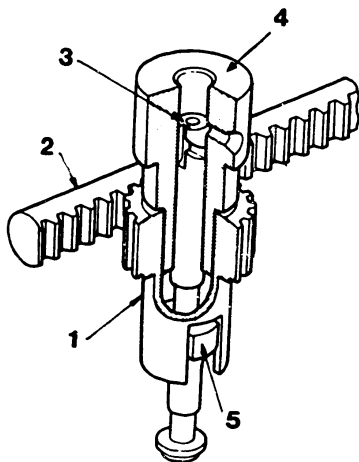

Fig. 7

- 1 = Control sleeve
- 2 = Control rack
- 3 = Plunger
- 4 = Plunger barrel
- 5 = Flange

Fuel variation mechanism

As well as pressurizing the fuel oil, the injection pump also functions to vary the fuel injection quantity.

A control sleeve is installed around the plunger barrel, and a flange on the bottom of the plunger is inserted into a groove in the control sleeve.



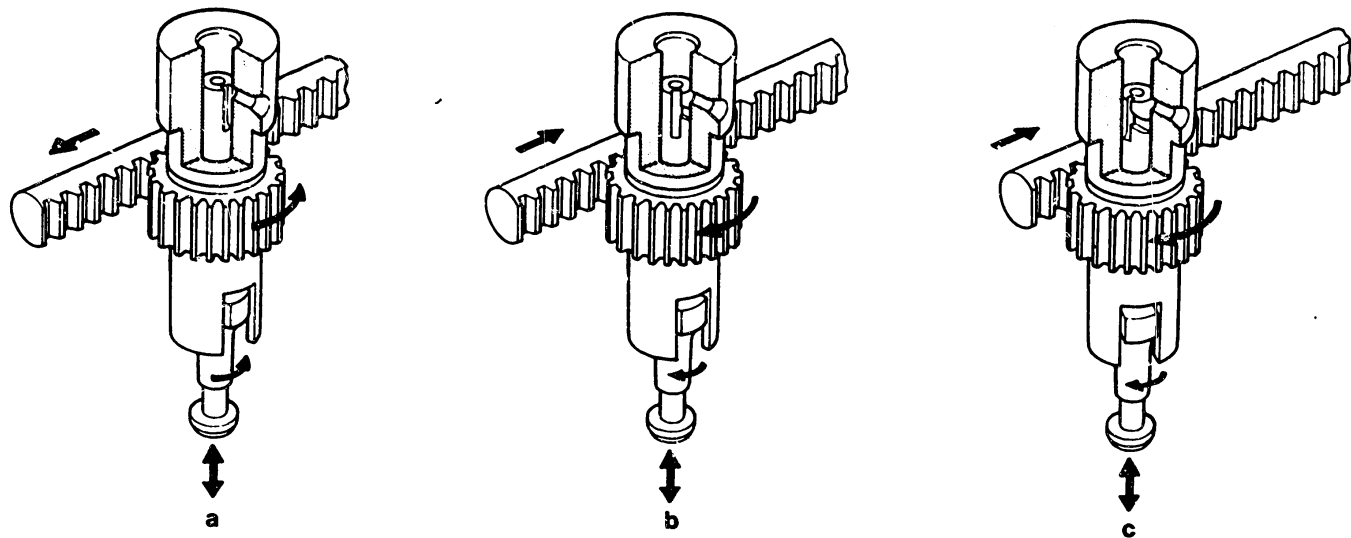

Fig. 8 Fuel variation mechanism

a = Non delivery

b = Partial delivery

c = Maximum delivery

Teeth on the control sleeve are engaged with teeth on the control rack so that movement of the control rack results in rotation of the plunger and, consequently, variation of the fuel injection quantity.

A17

Construction and operation
Fuel injection pump (PFR-KX)



A18

Construction and operation
Fuel injection pump (PFR-KX)



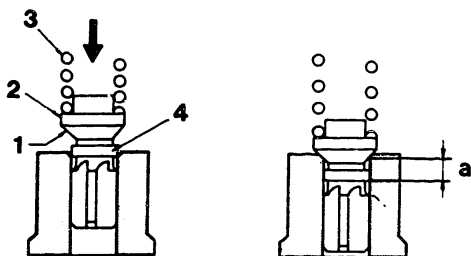

Fig. 9 Delivery valve assembly

- 1 = Seat portion a = Retraction stroke
 2 = Delivery valve
 3 = Delivery valve spring
 4 = Piston

The delivery valve assembly consists of the delivery valve and the valve seat.

When the force of the high-pressure fuel oil delivered by the plunger exceeds the force of the delivery valve spring, the delivery valve opens and fuel oil is delivered through the injection pipe to the nozzle holder.



Delivery valve assembly (continuation)

After injection, the injection pipe retains a degree of residual pressure adequate for the subsequent injection. The delivery valve prevents the reverse flow of this fuel oil in the injection pipe to the piunger side.

If the residual pressure is too high, then the flow of fuel oil will not be properly cut after injection.

By allowing the fuel oil in the injection pipe to retract an amount equal to the piston's retraction stroke, the delivery valve improves the ability of the nozzle to cut injection, as well as preventing dribbling.

A20

Construction and operation

Fuel injection pump (PFR-KX)



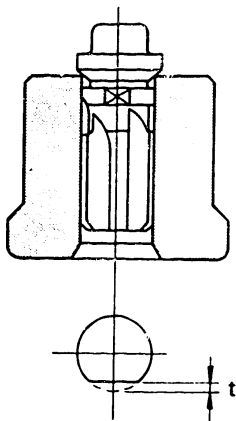

Fig. 10 Delivery valve (for variable retraction pistons)

t = Retraction piston diameter "shaved" amount

As can be seen in Figure 10, the delivery valve's piston has been chamfered. As delivered fuel escapes from this chamfer at low speeds, valve lift is smaller than that of the standard delivery valve. This results in a smaller retraction stroke and therefore a residual pressure appropriate for the subsequent injection can be retained in the injection pipe.



Delivery valve (for variable retraction
pistons (continuation))

At high speeds, however, the throttling effect of the chamfer causes a decrease in the quantity of fuel escaping and an end to the effect of the chamfer. The delivery valve then operates in the same way as the standard delivery valve.



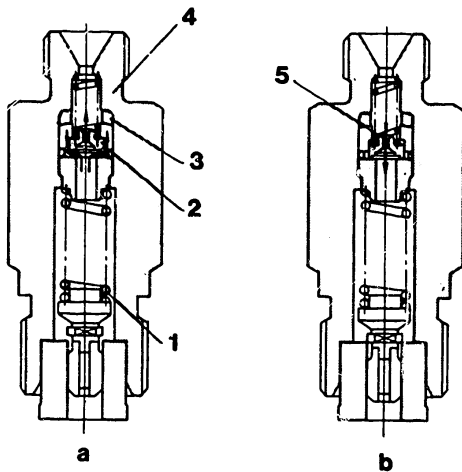

Fig. 11 Damping valve equipped delivery valve holder

- 1 = Delivery valve spring
- 2 = Damping valve
- 3 = Spacer
- 4 = Delivery valve holder
- 5 = Orifice

a = open

b = closed

The delivery valve holder equipped with a damping valve functions to prevent cavitation in the injection pipe, irregular injection, and secondary injection during high-speed operation.



Damping valve equipped delivery valve holder
(continuation)

When high-pressure fuel is delivered from the plunger, the delivery valve is opened. Because the damping valve is also opened at the same time, most of the fuel oil flows past the outside of the damping valve to the nozzle. After injection, however, as the damping valve closes more quickly than the delivery valve, fuel oil can only flow through the damping valve's small orifice. Because of this the delivery valve seats more slowly, preventing any sudden decrease in the pipe's in-line pressure.

At the same time, pressure wave surges in the pipe are suppressed, enabling stabilized injection.



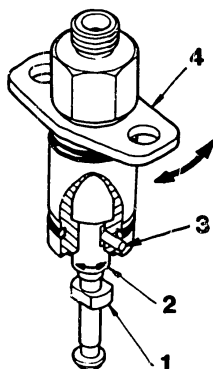

Fig. 12 Injection quantity adjustment mechanism

- 1 = Plunger
- 2 = Plunger barrel
- 3 = Pin
- 4 = Sleeve flange

The plunger barrel is fixed to the sleeve flange by a pin.

Because the plunger barrel also rotates when the sleeve flange is rotated, the relationship between the positions of the plunger helix and the plunger barrel's suction and discharge port changes, as does the effective stroke.

For example, when a right-hand helix plunger's sleeve flange is rotated clockwise, the effective stroke is increased, thereby increasing the fuel injection quantity.



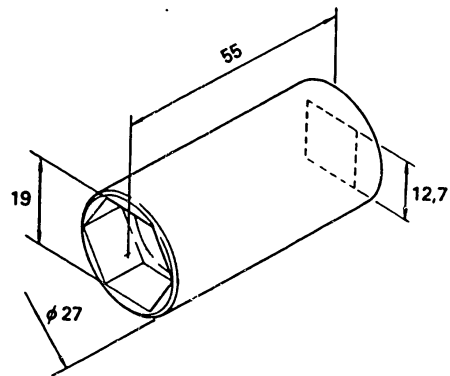

1

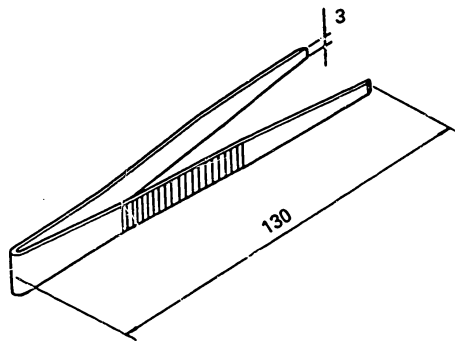

2

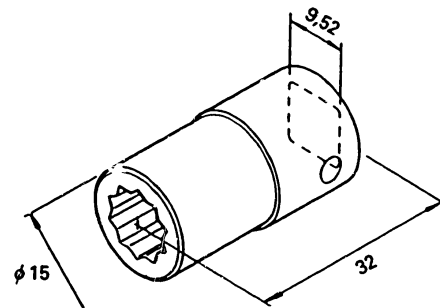

3

Fig. 13 Special tools for disassembly and reassembly

1 = Socket wrench

2 = Pincette

3 = Wrench

SPECIAL TOOLS

Disassembly and reassembly tools

The following special tools (in addition to general tools) are required for disassembly and reassembly of the PFR-KX type fuel injection pump.

No.	Tool name	Remarks
1	Socket wrench	For removing and installing delivery valve holders
2	Pincette	For removing and installing control sleeves, plungers etc.
3	Wrench	For removing and installing sleeve flanges' fixing bolts

A26

Special tools

Fuel injection pump (PFR-KX)



A27

Special tools

Fuel injection pump (PFR-KX)



Special tools for adjustment

In addition to the pump test stand, the following special tools are required for adjustment of the PFR-KX type fuel injection pump.

Key No.	Part number	Tool name	Remarks
1		Driving stand	For driving PFR 1 KX to 6 KX pumps
2		Holder	For mounting PFR 5 KX and 6 KX pumps
3		Nozzle, Nozzle holder assembly	Nozzle opening pressure: 133^{+3} kg/cm ³
4	1 680 750 014	Injection pipe	$\emptyset 2 \times \emptyset 6 - 600$ mm (M 14 x 1.5 - M 12 x 1.5)
5		Wrench	For discharging air from test nozzle holder
6	KDDC 0010	Measuring device	For measuring pre-stroke
7	KDDC 0012	Measuring device	For measuring control rack travel
8		Eye	For connecting pipe to test oil supply port
9		Gasket	For use with above eye
10		Eye bolt	For use with above eye

Note: The driving stand can be used to drive the PFR-K, PFR-KD und PFR-MD type fuel injection pumps as well as the PFR-KX type pump.

Refer to coord. B 9 to B 14 for the component parts (marked \bigcirc in Fig. 15) necessary to drive the PFR-KX type fuel injection pump, and coord. B 15 to B 21 for their usage.

B1

Special tools

Fuel injection pump (PFR-KX)

B2

Special tools

Fuel injection pump (PFR-KX)



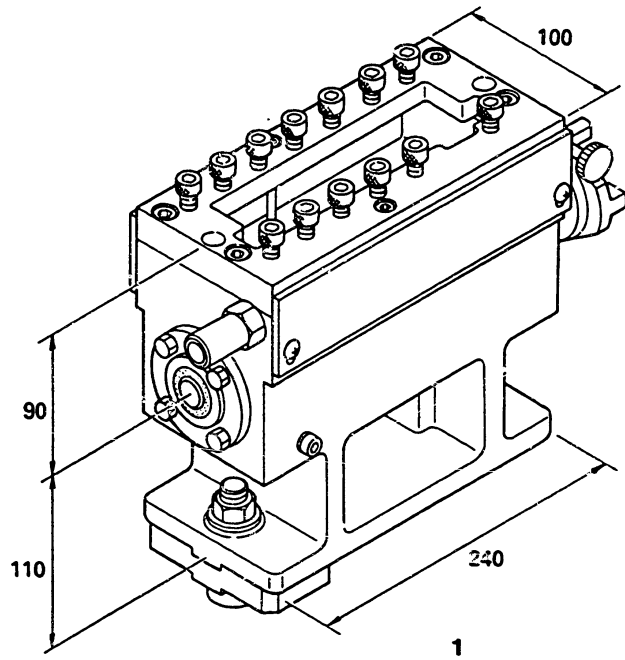

1

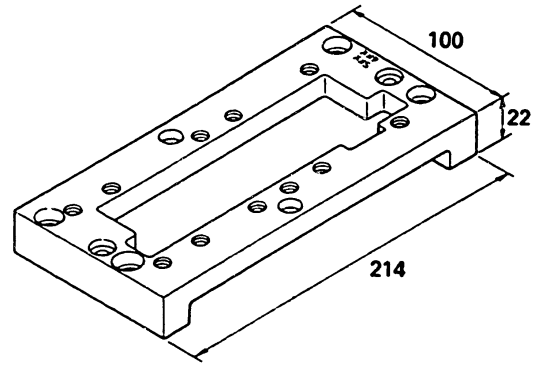

2

Fig. 14-1 Special tools for adjustment

1 = Driving stand

2 = Holder

B3	Special tools	↔
	Fuel injection pump (PFR-KX)	

B4	Special tools	↔
	Fuel injection pump (PFR-KX)	

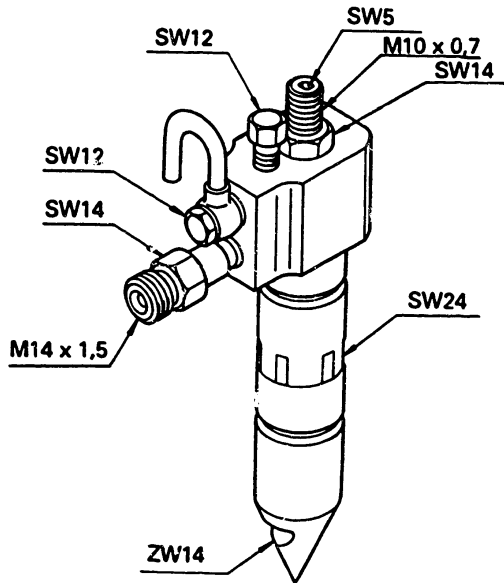

3

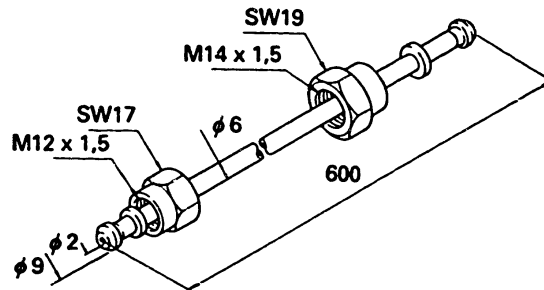

4

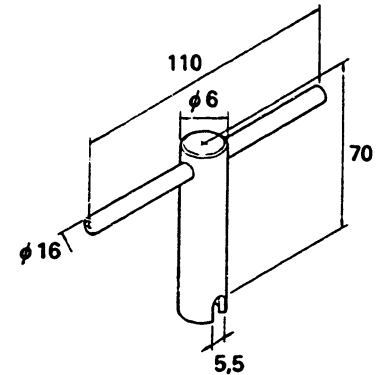

5

Fig. 14-2 Special tools for adjustment

3 = Nozzle and nozzle holder, compl.

4 = Injection pipe

5 = Wrench

1 680 750 014

B5

Special tools

Fuel injection pump (PFR-KX)



B6

Special tools

Fuel injection pump (PFR-KX)



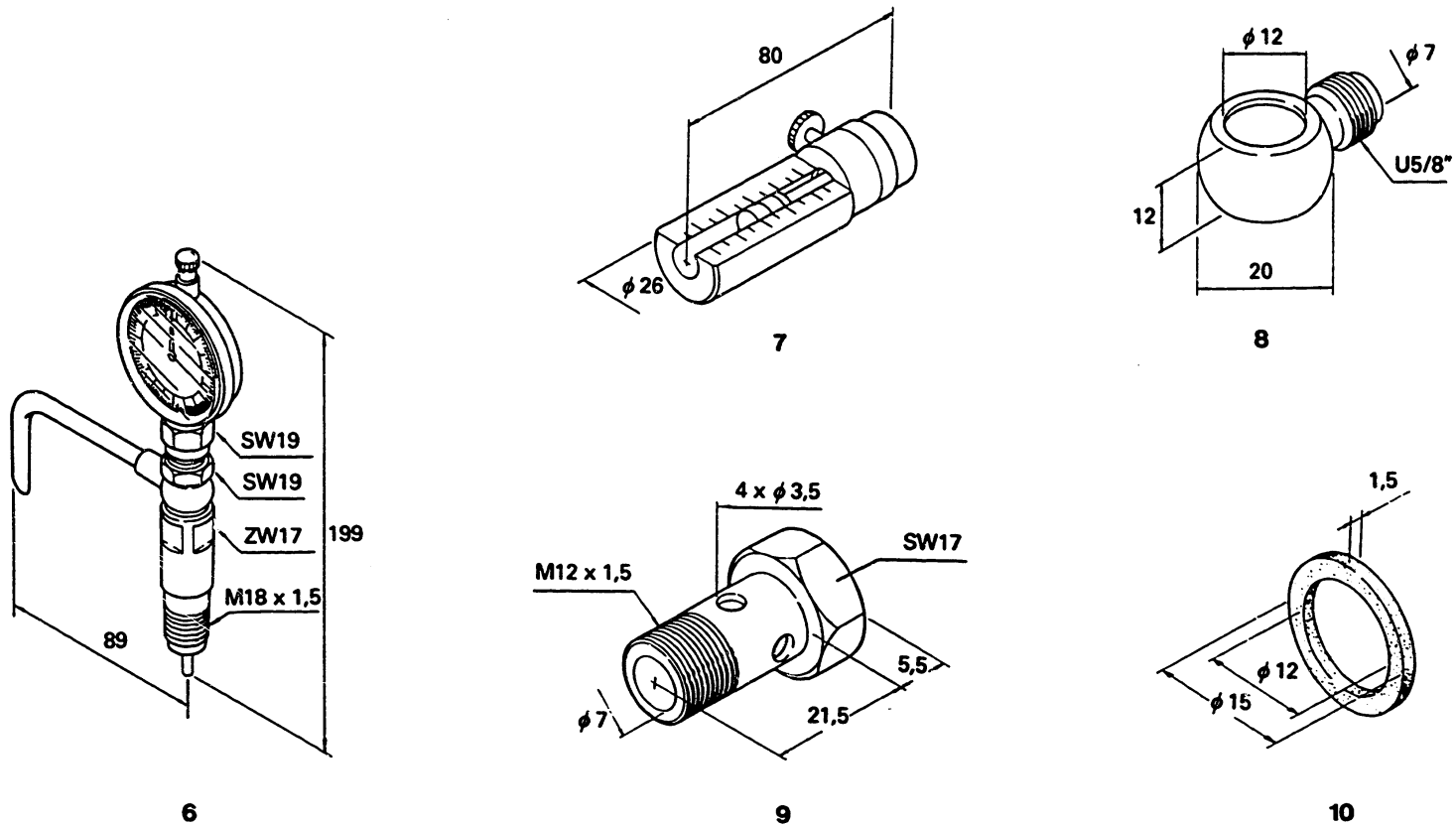

Fig. 14-3 Special tools for adjustment

6 = Measuring device KDDC 0010

7 = Measuring device KDDC 0012

8 = Eye

9 = Gasket

10 = Eye bolt

B7

Special tools

Fuel injection pump (PFR-KX)



B8

Special tools

Fuel injection pump (PFR-KX)

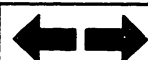

Component parts of the driving stand for PFR-KX type pump adjustment

No.	Part Name	Q'ty	Remarks
2A	Camshaft ass'y	1	For PFR-KX, K and KD pumps
3	Bolt	8	For fixing bearing cover
4	Coupling	1	For connecting pump test stand's drive-shaft
5	Spring washer	1	For fixing coupling
6	Nut	1	For fixing coupling
7	Control rack	1	
8A	Connector	1	For connecting PFR-KX and KD pump's control rack (rod)
9	Bolt	1	For fixing connector (key no. 8A)
10	Bushing	1	For installing control rack travel measuring device
11	Washer	A/R	For adjusting distance between collar and holder (thickness : 0.8 mm)
11	Washer	A/R	t = 0.35 mm
11	Washer	A/R	t = 0.5 mm
11	Washer	A/R	t = 1.0 mm
12A	Collar	2	For mounting PFR-KX and KD pumps (length : 43 mm)
13A	Holder	1	For mounting PFR 2 KX to 4 KX pumps and PFR 2 KD to 6 KD pumps
13B	Holder	1	For mounting PFR 1 KX and PFR 1 KD pumps
14A	Socket head bolt	2	For fixing holders for PFR-KX and KD pumps (length : 66 mm)
15A	Socket head bolt	2	For fixing holders for PFR-KX and KD pumps (length : 33 mm)
16	Dowel pin	2	For aligning holders
17	Screw	1	For fixing control rack

B9

Special tools

Fuel injection pump (PFR-KX)



B10

Special tools

Fuel injection pump (PFR-KX)



Component parts of the driving stand for PFR-KX type pump adjustment (continuation)

No.	Part Name	Q'ty	Remarks
18	Oil level gauge	1	For checking lubricating oil level
19	Gasket	1	Used together with socket head bolt (key no. 20)
20	Socket head bolt	1	For lubricating oil drain
21	Cover	2	For covering stand's side portion
22	Screw	4	For fixing cover
23	Bolt	2	For fixing stand (length : 70 mm)
24	Washer	2	Used together with bolt (key no. 23) and nut (key no. 25)
25	Nut	2	Used together with bolt (key no. 23) and washer (key no. 24)
26A	Socket head bolt	13	For fixing PFR-KX and KD pumps (thread : M 8 x 1.25 mm, length : 28 mm)
27	Adapter	2	Thickness : 15 mm

B11

Special tools

Fuel injection pump (PFR-KX)



B12

Special tools

Fuel injection pump (PFR-KX)



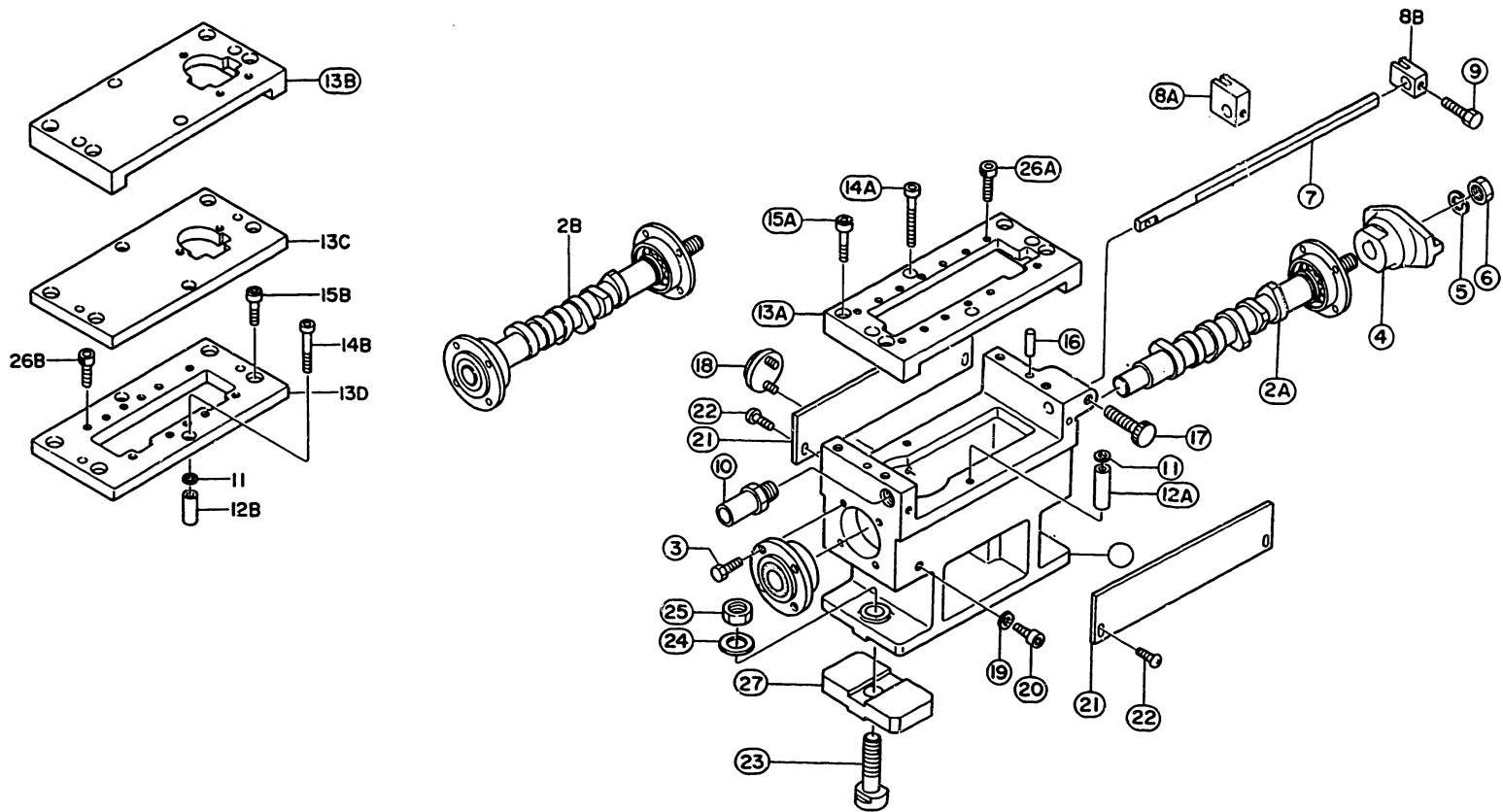

Fig. 15 Exploded view of the driving stand

B13

Special tools

Fuel injection pump (PFR-KX)



B14

Special tools

Fuel injection pump (PFR-KX)



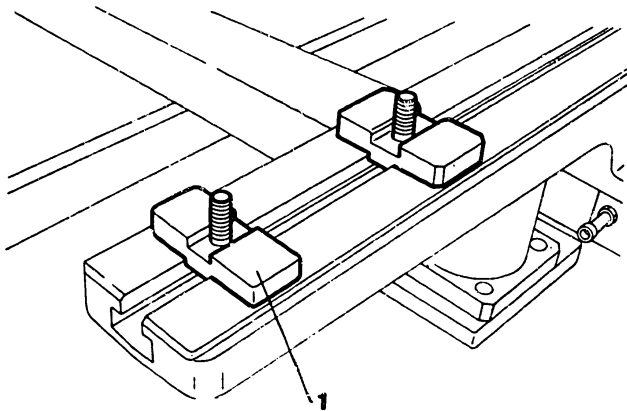

Fig. 16 Installing the adapters

1 = Adapter

Driving stand usage

1. Adapter

When using the pump test stand with a center height of 125 mm, the two adapters (27) should be installed between the pump test stand's bed and the stand (1). (Figure 16).

Note:

The numbers in parentheses following part names refer to the key numbers in Fig. 15.



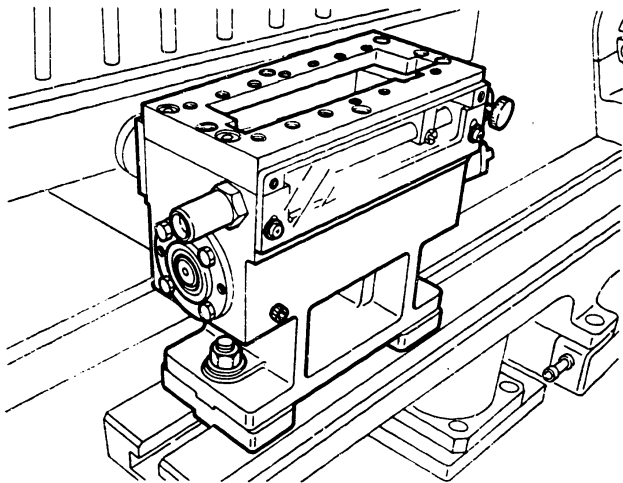

Fig. 17 Installing the driving stand

2. Install the driving stand on the pump test stand's bed. (Figure 17).
3. Check the distinguishing marks on the camshaft (2A) and holder to determine the correct holder to be used.
The pumps' type numbers are stamped on the holders.



Distinguishing marks		Holder key No.
Camshaft	Holder	
6KD	2~4KX,2~6KD	13A
	KX,KD	13B
	5KX,6KX	*

*

The holder for PFR 5 KX and 6 KX type pumps is not included with the driving stand.

It must be purchased separately.

B17

Special tools

Fuel injection pump (PFR-KX)



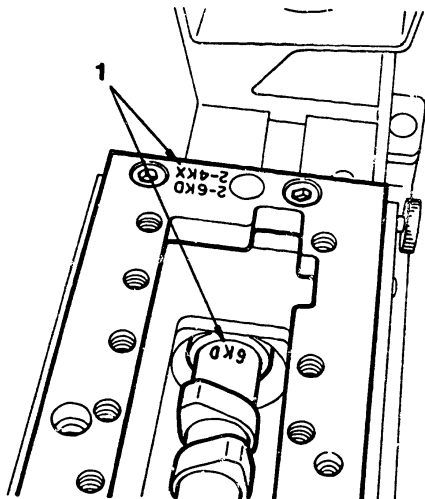

Fig. 18 Confirming the distinguishing marks

1 = Distinguishing mark

Fig. 18 shows the camshaft and holder for driving the PFR 2 KX to 4 KX pumps.



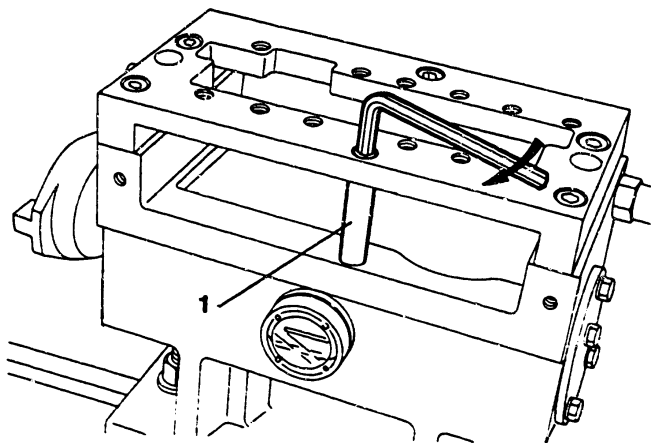

Fig. 19 Installing the collar

1 = Collar

- 4.** Install the two collars (12A) between the holder (13A) and the stand (1) as shown in Figure 19.

If the clearance between the holder and the collar is excessive, adjust the clearance using the washer (11).



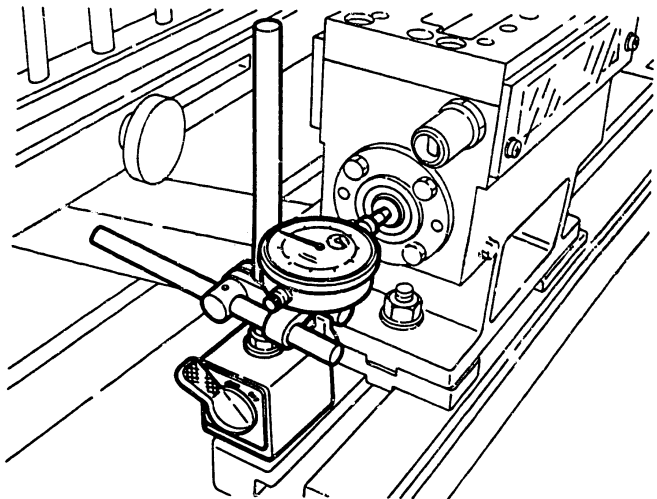

Fig. 20 Measuring the camshaft's axial play

5. Measure the camshaft's axial play and confirm that it is as specified.
(Figure 20)

Specified value: 0.03 to 0.05 mm

6. If the axial play is not as specified, correct it by changing the thickness of the adjusting shim.



Adjusting shims

* Part No.	Thickness (mm)	Remarks
029311-7010	0.10	
029311-7020	0.12	
029311-7030	0.14	Outer diameter
029311-7040	0.16	ø22 mm
029311-7050	0.18	
029311-7060	0.5	Inner diameter
029311-7070	1.0	ø17 mm
029311-7090	0.3	
029311-7210	0.7	
029311-7220	1.4	
139417-0000	2.4	

*) Bosch Nr., see cross reference DKKC - BOSCH, microfiche HB 30, HB 31.

B21

Special tools

Fuel injection pump (PFR-KX)



DISASSEMBLY

1. Since the injection pump is constructed of precision components, special care must be taken during handling.
2. Before disassembly clean any engine oil or dirt from the injection pump.
3. During disassembly place the parts removed from each cylinder in a line on the bench so that they can be reassembled in the correct cylinder during reassembly. Never change the plunger/plunger barrel and delivery valve/delivery valve seat combinations.

Disassembly of the PFR 3 KX type injection pump is explained following. The numbers in parentheses following the part names indicate the key numbers in Fig. 21, and those following the tool names indicate the tools' part numbers.

B 22

Disassembly

Fuel injection pump (PFR-KX)



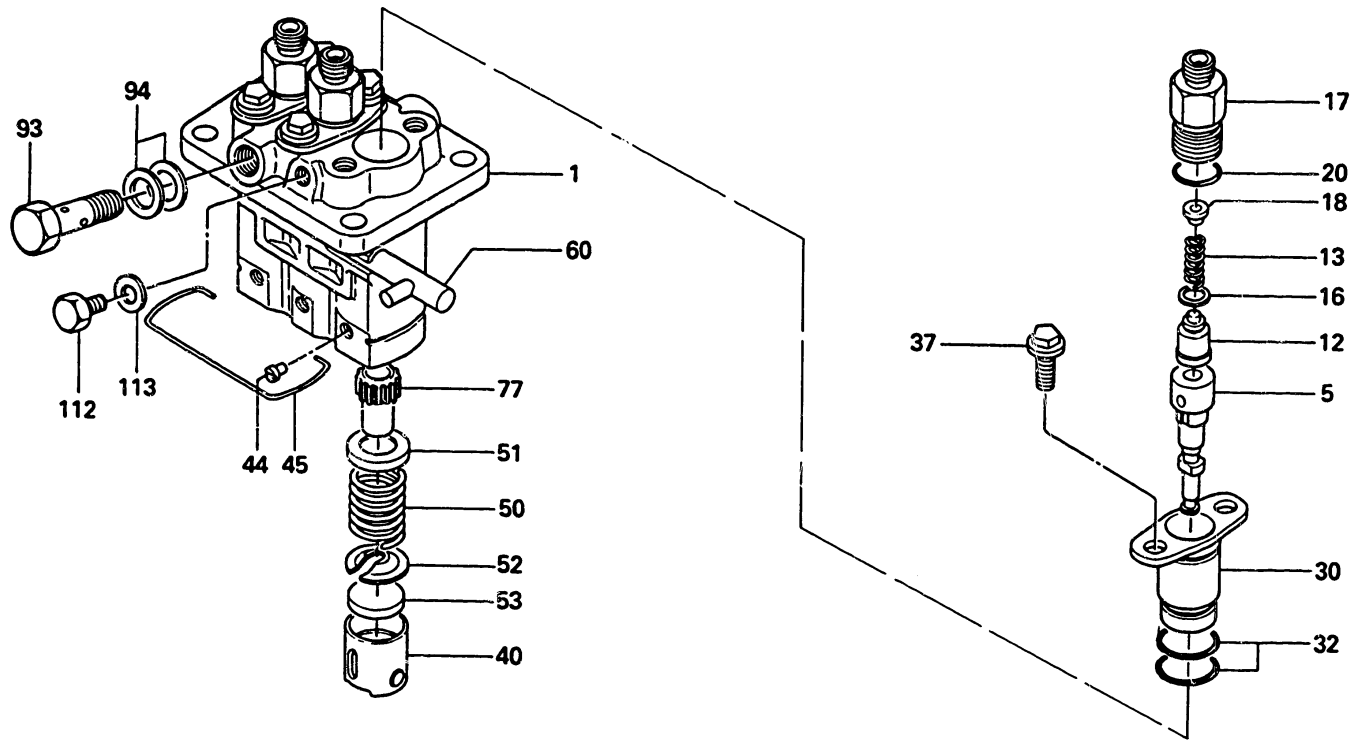

Fig. 21 Exploded view

1 - 113 = Key No.

- 1 = Pump housing
- 5 = Plunger assembly
- 12 = Delivery valve assembly
- 13 = Delivery valve spring
- 16 = Gasket
- 17 = Delivery valve holder
- 18 = Delivery valve spring seat
- 20 = O-ring

- 30 = Sleeve flange
- 32 = O-ring
- 37 = Bolt
- 40 = Tappet assembly
- 44 = Pin
- 45 = Snapring
- 50 = Plunger spring
- 51 = Spring seat

- 52 = Spring seat
- 53 = Plate
- 60 = Control rack
- 77 = Control sleeve
- 93 = Eye bolt
- 94 = Gasket
- 112 = Bolt
- 113 = Gasket

B23

Disassembly
Fuel injection pump (PFR-KX)



B24

Disassembly
Fuel injection pump (PFR-KX)

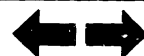

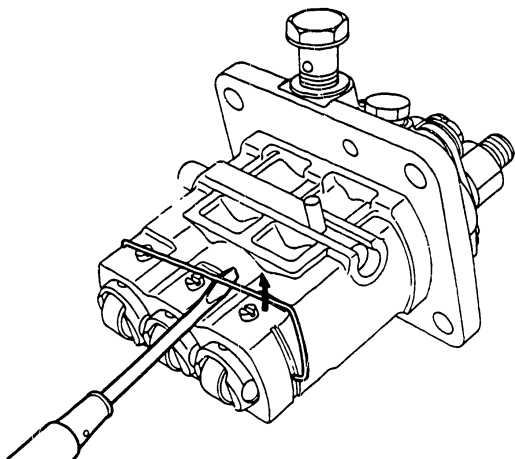

Fig. 22 Removing the snapping

1. Remove the snapping (45) from the pump housing (1).



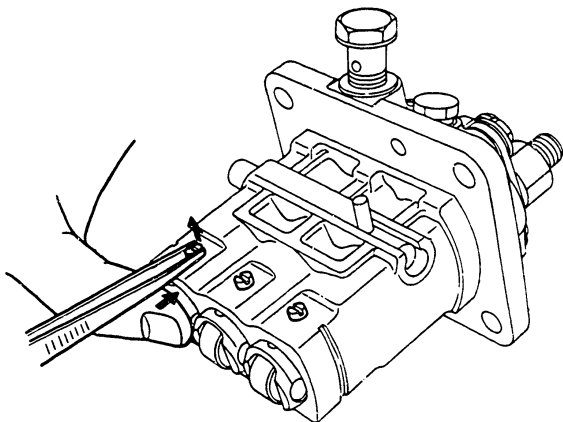

Fig. 23 Removing the pin

2. Press the tappet (40) and remove the pin (44).



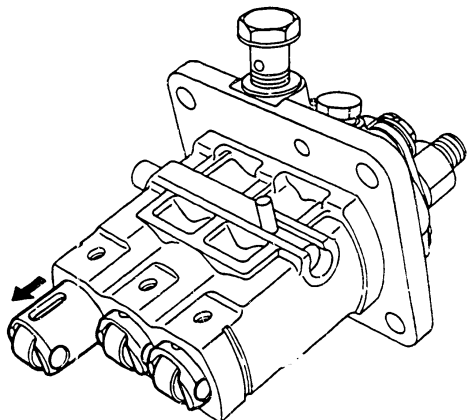

Fig. 24 Removing the tappet

3. Remove the tappet (40) and the plate (53).

B27

Disassembly

Fuel injection pump (PFR-KX)



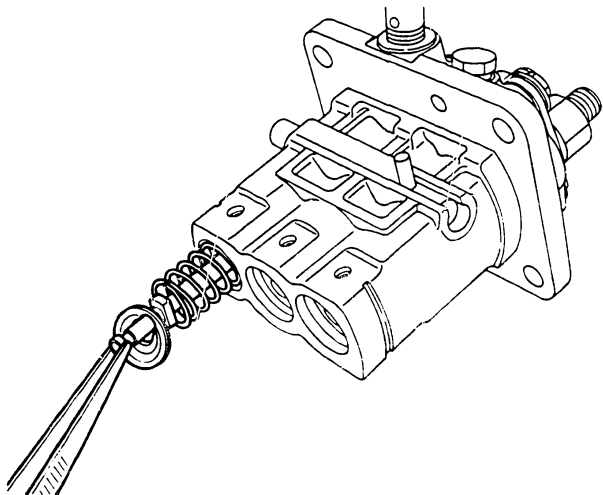

Fig. 25 Removing the plunger

4. Remove the plunger (5), the spring seat (52) and the plunger spring (50).

Note: Place the plungers in clean fuel oil in the cylinder number sequence.



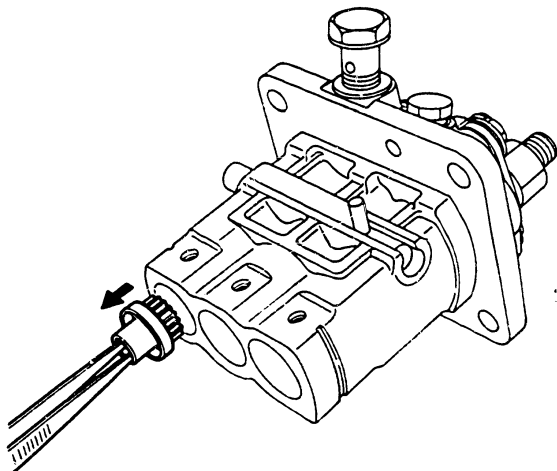

Fig. 26 Removing the control sleeve

5. Remove the control sleeve (77) and the spring seat (51).

C1

Disassembly

Fuel injection pump (PFR-KX)



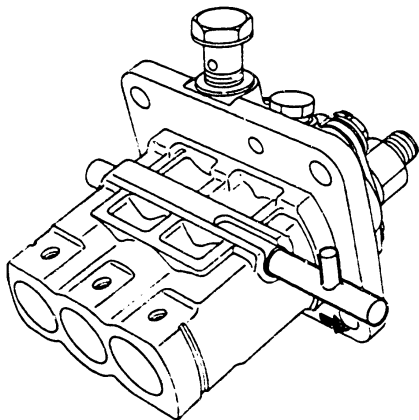

Fig. 27 Removing the control rack

6. Remove the control rack (60) from the pump housing (1).



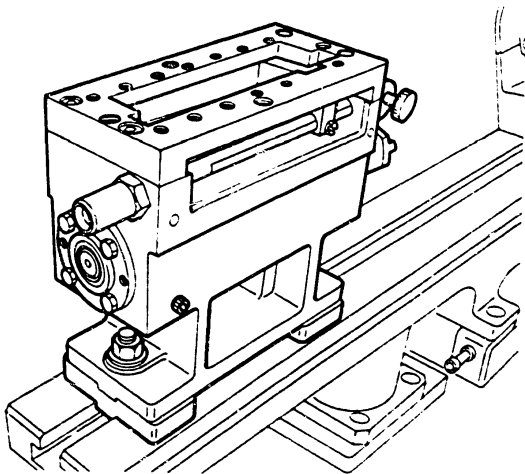

Fig. 28 Driving stand

7. Fix the driving stand to the pump test stand.

Disassembly is simplified if the adjustment driving stand is used after sleeve flange disassembly.

The procedure is described following.



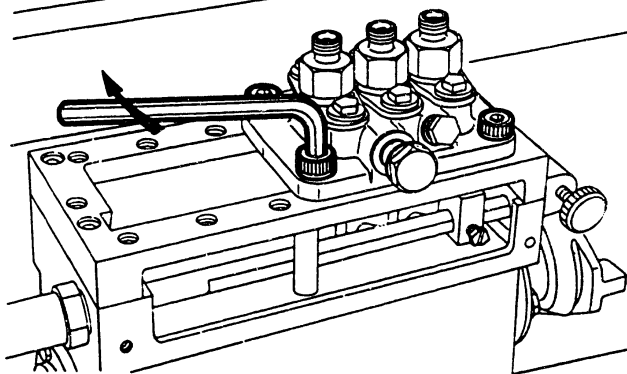

Fig. 29 Mounting the injection pump

8. Mount the injection pump on the driving stand.

C4

Disassembly

Fuel injection pump (PFR-KX)



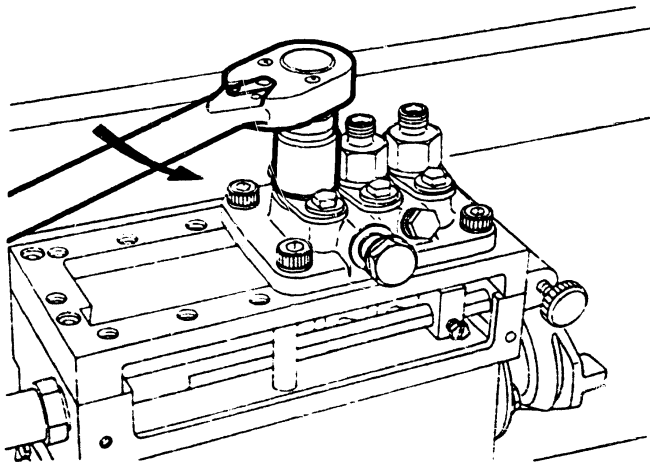

Fig. 30 Loosening the delivery valve holder

9. Loosen the delivery valve holder using a wrench.

C5

Disassembly

Fuel injection pump (PFR-KX)



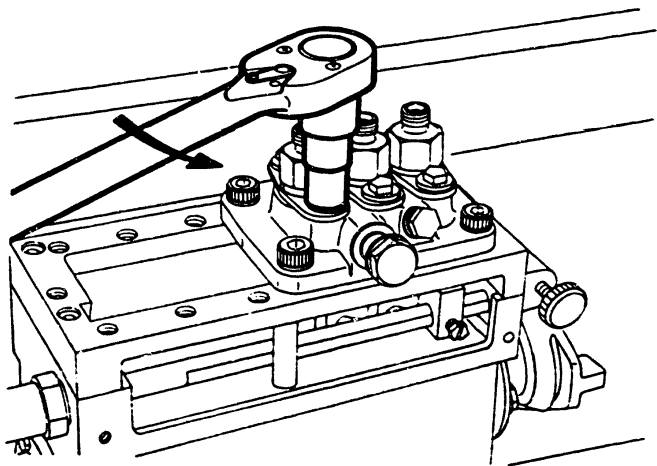

Fig. 31 Removing the sleeve flange bolts

10. Remove the five-sided bolts (37) using a wrench.



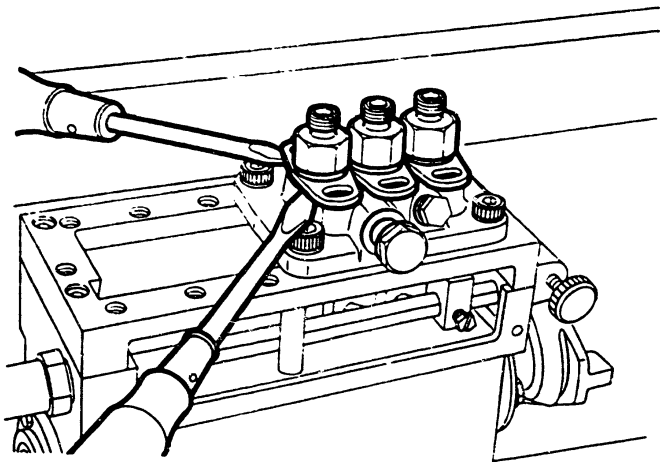

Fig. 32 Loosening the sleeve flange

- 11.** Insert screwdrivers between the sleeve flange (30) and the pump housing and lever the sleeve flange up.

Note: Be careful not to damage the pump housing.



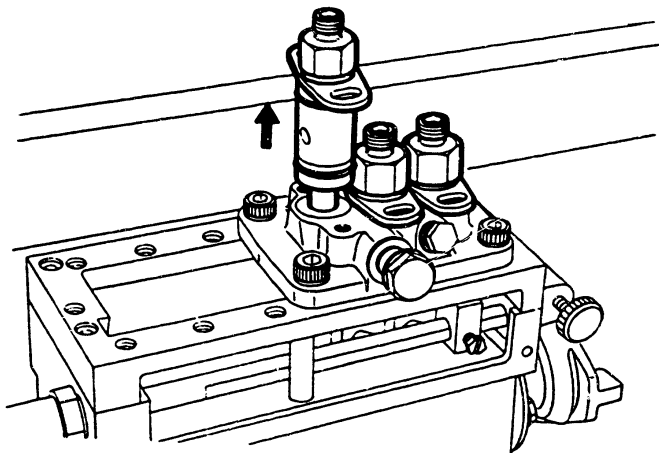

Fig. 33 Removing the sleeve flange

12. Remove the sleeve flange from the pump housing.



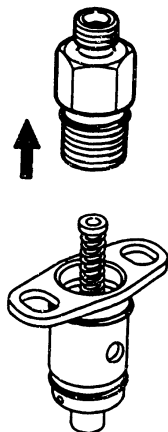

Fig. 34 Removing the delivery valve holder

13. Remove the delivery valve holder (17) from the sleeve flange (30).



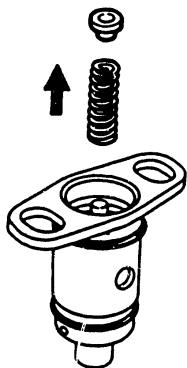

Fig. 35 Removing the spring and spring seat

14. Remove the delivery valve spring (13) and the delivery valve spring seat (18).



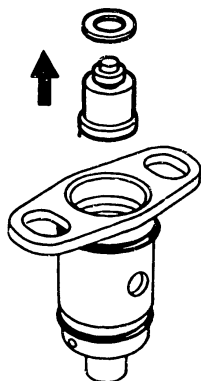

Fig. 36 Removing the gasket and the delivery valve assembly

15. Remove the delivery valve assembly (12) and the gasket (16) together.



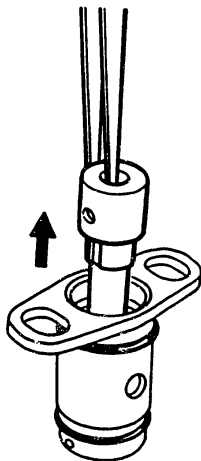

Fig. 37 Removing the plunger barrel

16. Remove the plunger barrel from the sleeve flange and place it in clean fuel oil with the previously removed plunger. (Figure 37)

Note: Do not place the plunger barrel with a different plunger.

17. Finally, remove the six O-rings (32) to complete disassembly of the PFR3KX type injection pump. Disassembly of PFR-KX type injection pumps with differing numbers of cylinders can be performed in the same way.



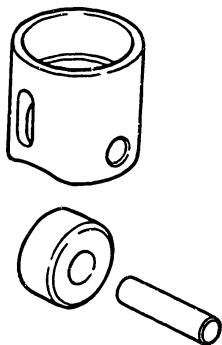

Fig. 38 Tappet, roller and roller pin

INSPECTION

Pump housing

If the pump housing is cracked, worn or has damaged threads, it must be replaced.

Tappets

If the outside of the tappet, roller or pin is scratched, worn excessively, peeling or scorched, the tappet must be replaced.



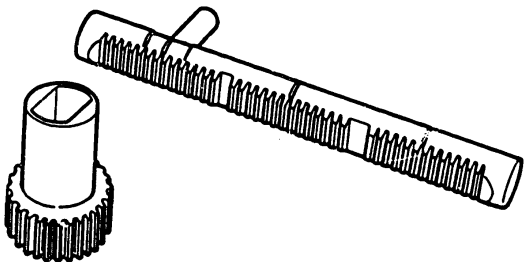

Fig. 39 Control rack and control sleeve

Control rack

If the control rack is bent or damaged, or its teeth are worn excessively, it must be replaced.

Control sleeve

If the teeth or grooves are worn excessively, replace the control sleeve.



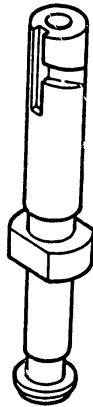

Fig. 40 Plunger

Plunger assembly

- 1. If the plunger helix is scratched, discolored or worn, replace the plunger assembly.**

C15

Inspection

Fuel injection pump (PFR-KX)



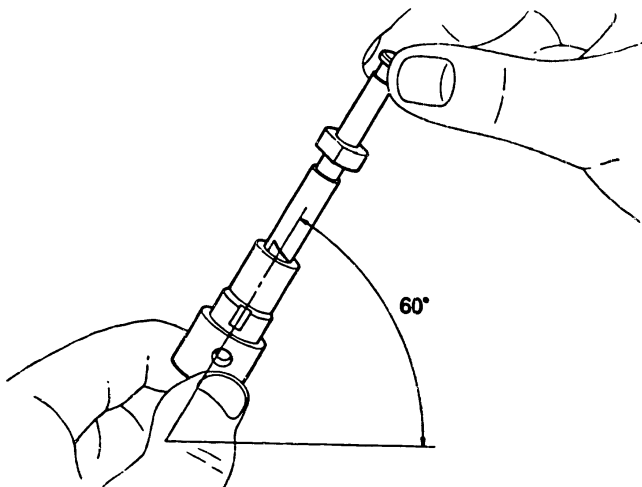

Fig. 41 Plunger inspection

2. After washing the plunger assembly in clean fuel oil, tilt the plunger assembly to approximately 60° , as shown in Figure 41. If the plunger slides down smoothly into the plunger barrel under its own weight, the condition of the assembly is considered satisfactory.

During this test rotate the plunger several times. If the plunger stops midway or slides down too fast, replace the plunger assembly.

C16

Inspection

Fuel injection pump (PFR-KX)





Fig. 42 Delivery valve inspection

Delivery valve assembly

1. If the piston or seat is scratched or worn, replace the delivery valve assembly.
2. After washing the delivery valve assembly in clean fuel oil, hold your thumb on the bottom of the delivery valve's body as shown in Figure 37. Then, press the delivery valve lightly with your finger. If the delivery valve springs back when you release your finger, the condition of the delivery valve is considered satisfactory. If the valve does not spring back, the piston is worn and the delivery valve assembly must be replaced.



Note: The procedure is not necessary if the delivery valve has a variable retraction type piston.

This type of piston will not return after your finger is released (it is not a defective part).

Gaskets and O-rings

Do not reuse gaskets and O-rings.
They must be replaced.

Other parts

Check each part carefully and replace any which are worn or damaged.

C18

Inspection

Fuel injection pump (PFR-KX)



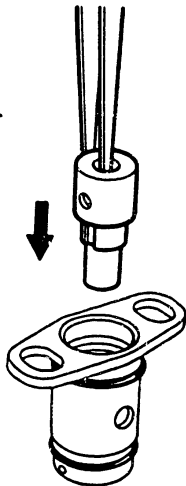

Fig. 43 Installing the plunger barrel

REASSEMBLY

The injection pumps' reassembly sequence is the reverse of disassembly.

However, points which require special care are explained following.

1. When installing the plunger barrel in the sleeve flange (30), fit the sleeve flange's press-fitted pin into the groove in the plunger barrel to fix the position of the plunger barrel (i.e. to prevent plunger barrel rotation).



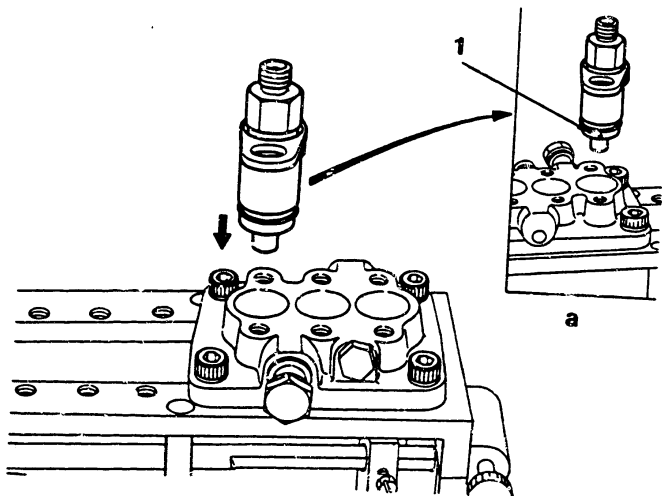

Fig. 44 Installing the sleeve flange

1 = Press-fitted pin
 a = View from A

2. When installing the sleeve flange assembly in the pump housing (1), position the sleeve flange's press-fitted pin away from the housing's control rack installation hole.



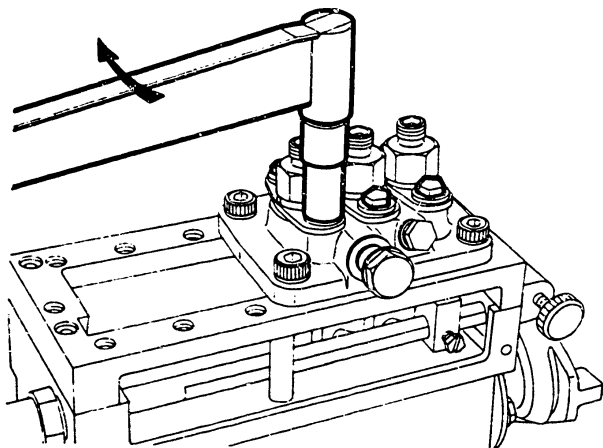

Fig. 45 Tightening the sleeve flange bolts

3. Tighten the five-sided bolts to the specified torque.

Tightening torque : 1.8 to 2.3 kg-m



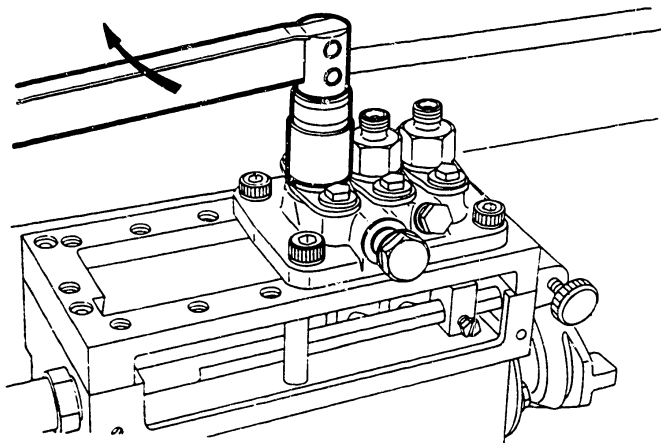
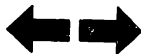

Fig. 46 Tightening the delivery valve holder

4. Tighten the delivery valve holders to the specified torque.

Tightening torque : 4.0 to 4.5 kg-m



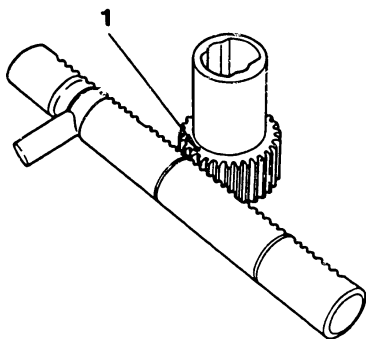

Fig. 47 Assembling the control sleeve and control rack

1 = Punch mark

5. When assembling the control sleeve and the control rack, align the line on the control rack with the punch mark on the control sleeve.



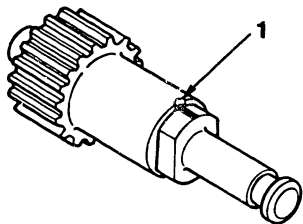

Fig. 48 Fitting the plunger

1 = "V" notch

6. When fitting the plunger into the plunger barrel, align the plunger's aligning mark with the control sleeve's "V" notch so that the plungers' helix correctly aligns with the plunger barrel's suction and discharge port.



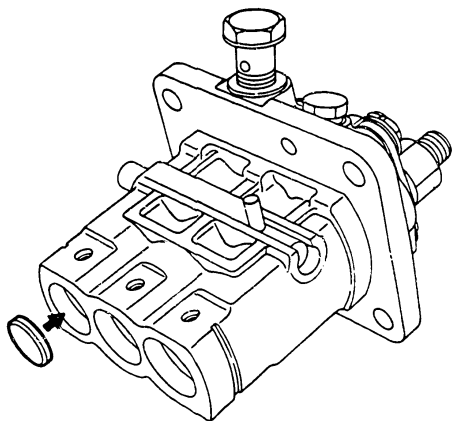

Fig. 49 Fitting the plate

7. Fit the plate (53) with the chamfered side facing the tappet.

C25

Reassembly

Fuel injection pump (PFR-KX)

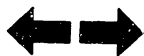

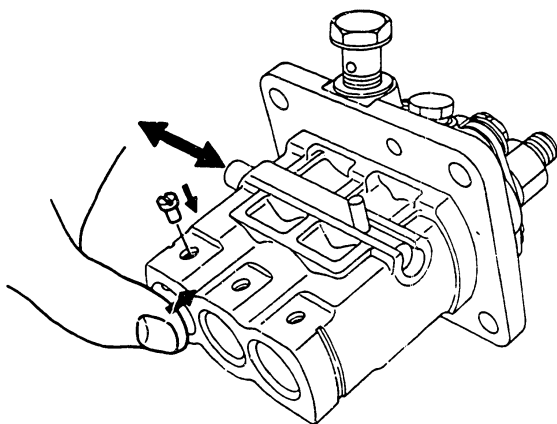

Fig. 50 Installing the pin

8. When inserting the pin (44) into the tappet, press the tappet while slowly moving the control rack to find where the plunger flange fits the control sleeve groove.



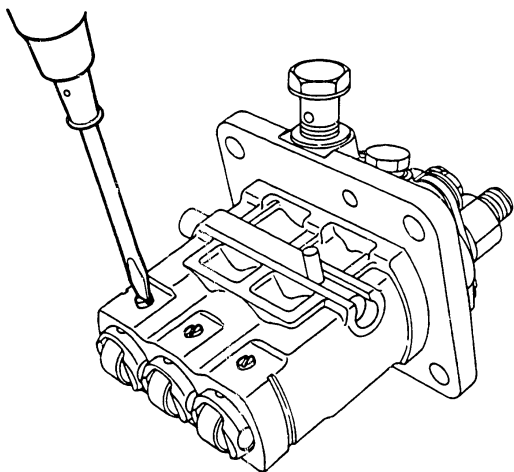

Fig. 51 Positioning the pins

9. Using a screwdriver, position the pins (44) so that their grooves are horizontal.



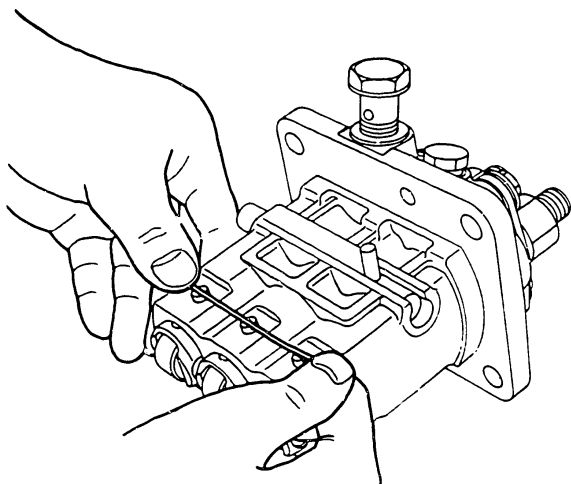

Fig. 52 Installing the snapping

10. Install the snapping (45) so that it is positioned in the pins' (44) grooves.



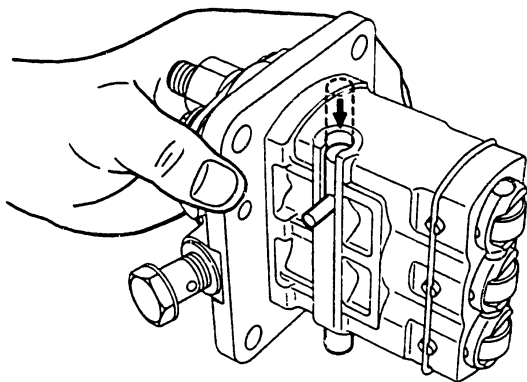

Fig. 53 Control rack inspection

- 11. After reassembly, tilt the injection pump as shown in Figure 48 and confirm that the control rack moves smoothly under its own weight.**

D1

Reassembly

Fuel injection pump (PFR-KX)



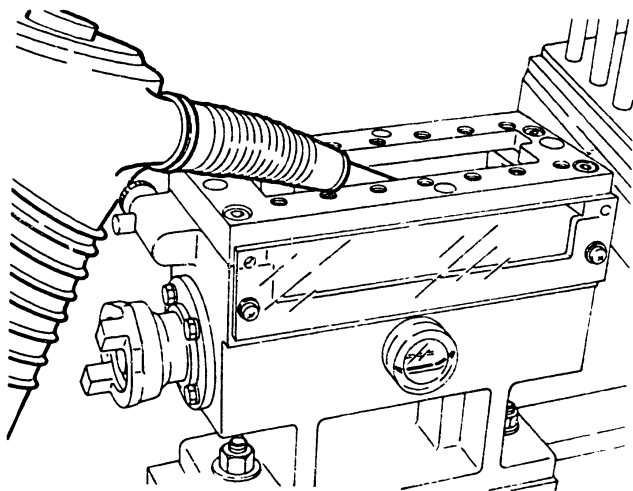

Fig. 54 Adding oil to the cam chamber

ADJUSTMENT

Preparation

1. Fill the driving stand's cam chamber with lubricating oil. (Figure 56)

Lubricating oil :
Injection pump oil

Oil level :
Between the "H" and "L" marks of the oil level gauge.

2. Remove the two plastic covers.



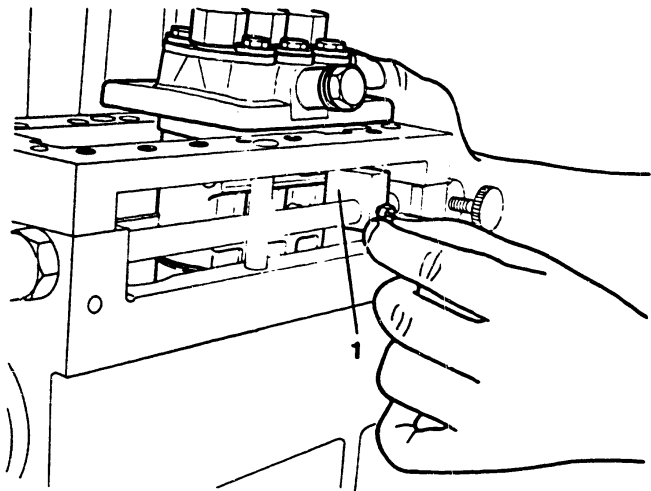

Fig. 55 Mounting the injection pump

1 = Connector

3. Attach the injection pump to the driving stand and confirm that the control rack pin is fitted into the connector's groove.

D3

Adjustment

Fuel injection pump (PFR-KX)



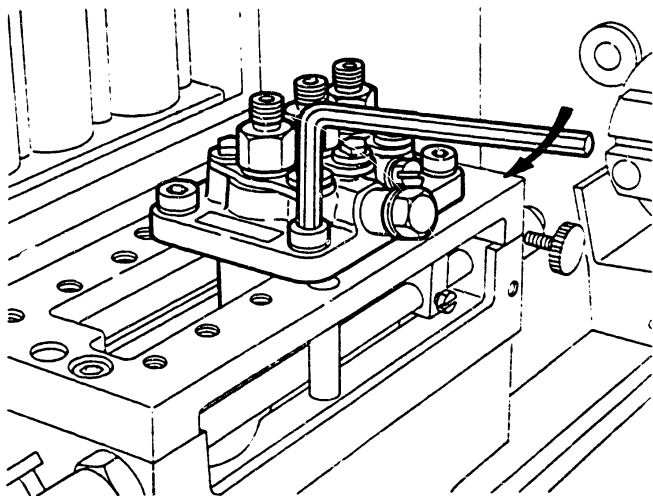

Fig. 56 Attaching the injection pump

4. Securely attach the injection pump to the holder using the socket head bolts. (Figure 56)
5. Rotate the camshaft manually one or two turns. Check that it rotates smoothly.



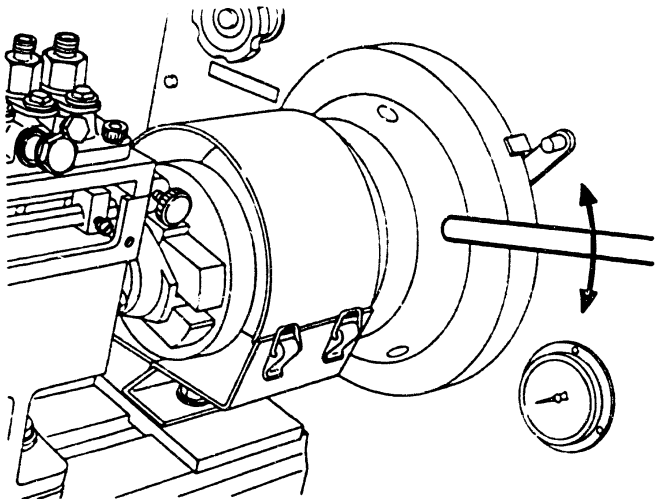

Fig. 57 Confirming flywheel rotation

6. Securely connect the driving stand's coupling to the pump test stand's coupling. (Figure 57)
7. After connecting the coupling, move the pump test stand's flywheel manually and confirm that it rotates smoothly.



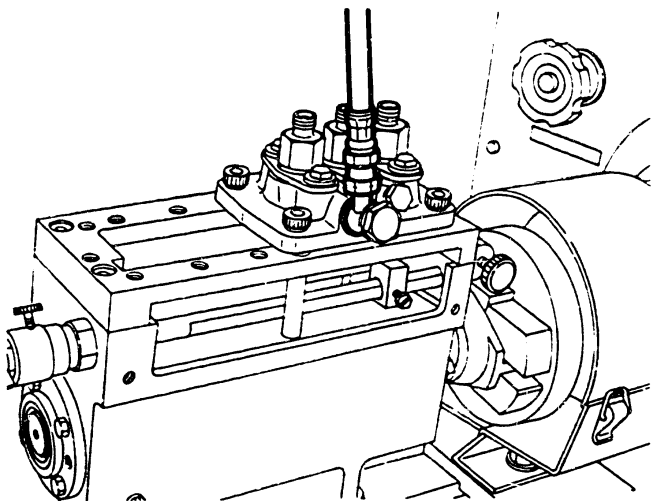

Fig. 58 Attaching the measuring device and supply hose

- 8. Attach the measuring device (KDDC 0012) to the driving stand and then connect the flexible fuel oil supply hose to the injection pump.**

D6

Adjustment

Fuel injection pump (PFR-KX)



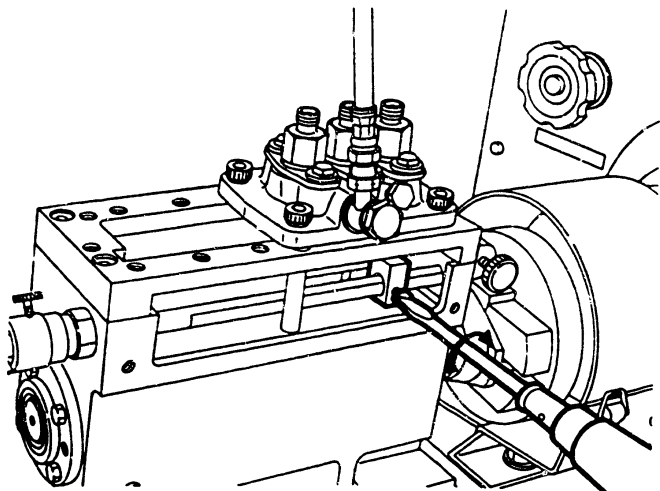

Fig. 59 Tightening the control rack guide

- 9. Fix the connector to the driving stand's control rack.**

D7

Adjustment

Fuel injection pump (PFR-KX)



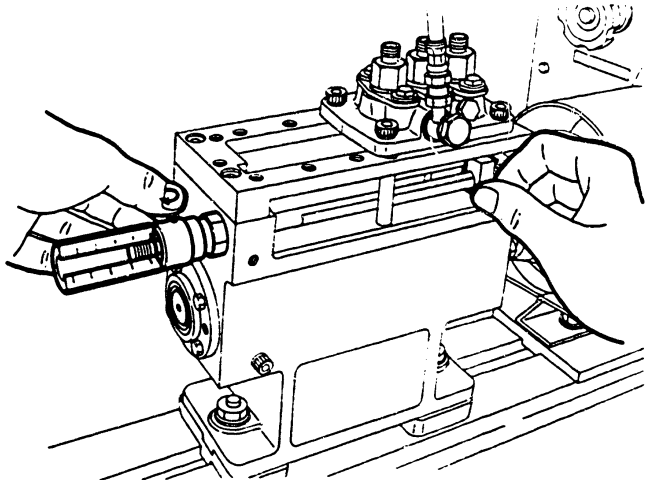

Fig. 60 Setting the measuring device to "0"

10. Push the control rack fully in the "stop" direction and set the measuring device's vernier scale to "0".

D8

Adjustment

Fuel injection pump (PFR-KX)



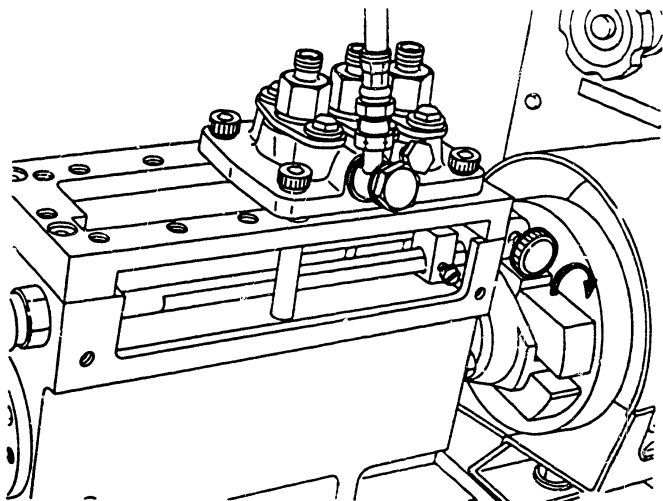

Fig. 61 Fixing the control rack

Injection timing adjustment

- 1. Fix the control rack in the position specified as "basic" in the calibration data.**

D9

Adjustment

Fuel injection pump (PFR-KX)



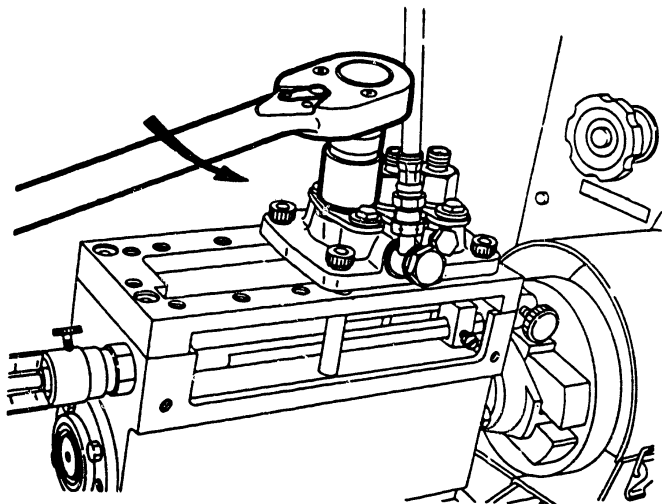

Fig. 62 Removing the delivery valve holder

2. Remove the delivery valve holder.

D10

Adjustment

Fuel injection pump (PFR-KX)



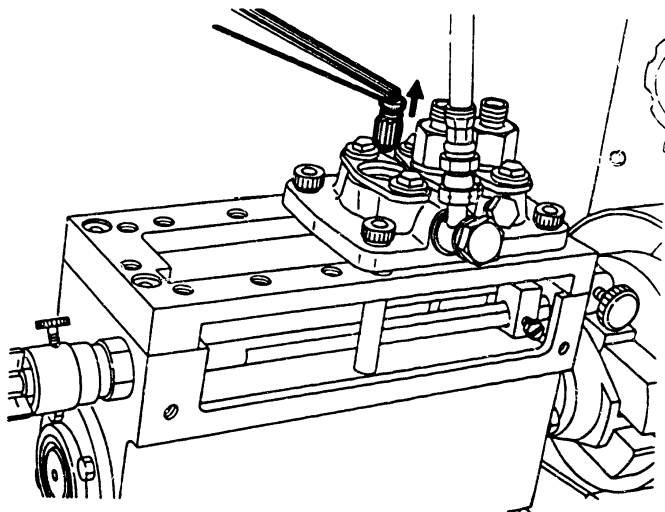

Fig. 63 Removing the delivery valve and spring

3. Remove the delivery valve spring and the delivery valve.

D11

Adjustment

Fuel injection pump (PFR-KX)

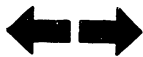

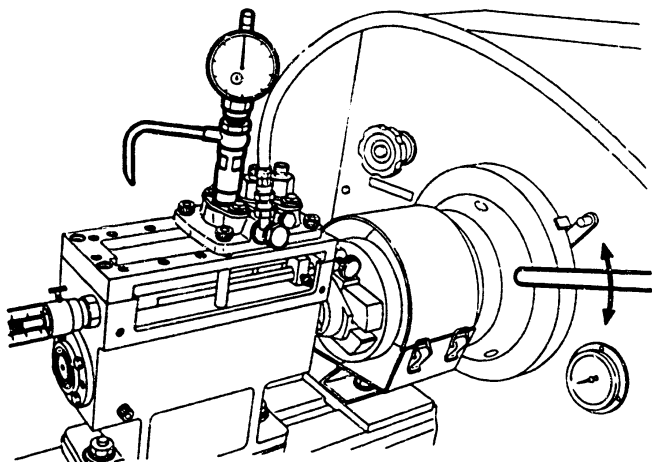

Fig. 64 Setting the dial gauge to "0"

4. Attach the measuring device (KDDC 0010) to the injection pump.

Move the pump test stand's flywheel manually to position the driving stand cam of the cylinder to be measured in the bottom dead center position. Then, set the dial gauge to "0".



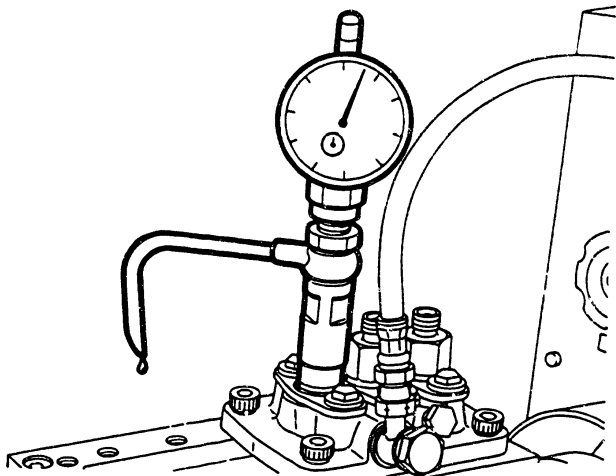

Fig. 65 Adjusting the pre-stroke

5. Adjust the fuel oil supply pressure to 0.2 kg/cm^2 and supply oil to the injection pump. Prepare a container to catch the fuel oil which will flow from the measuring device at this time.
6. Turn the flywheel slowly by hand in a clockwise direction (viewed from the drive side), and read the value indicated on the measuring device when the fuel oil stops flowing. (Figure 65)



Adjusting the pre-stroke (continuation)

If the reading is not within the pre-stroke values specified in the calibration data, replace the plate (53) and readjust the injection timing.

7. Attach the measuring device to the remaining cylinders and measure the pre-stroke in the same way.
8. After removing the measuring device, reinstall the delivery valve, delivery spring and the delivery valve holder. Tighten the delivery valve holder to the specified torque.

Tightening torque : 4.0~4.5 kg-m

D14

Adjustment

Fuel injection pump (PFR-KX)



Plates for injection timing adjustment

Thickness (mm)	* Part No.	Stamping	Thickness (mm)	* Part No.	Stamping
2.60	140217 -5000	260	3.40	140217 -6600	340
2.65	-5100	265	3.45	-6700	345
2.70	-5200	270	3.50	-6800	350
2.75	-5300	275	3.55	-6900	355
2.80	-5400	280	3.60	-7000	360
2.85	-5500	285	3.65	-7100	365
2.90	-5600	290	3.70	-7200	370
2.95	-5700	295	3.75	-7300	375
3.00	-5800	300	3.80	-7400	380
3.05	-5900	305	3.85	-7500	385
3.10	-6000	310	3.90	-7600	390
3.15	-6100	315	3.95	-7700	395
3.20	-6200	320	4.00	-7800	400
3.25	-6300	325	4.05	-7900	405
3.30	-6400	330	4.10	140217 -8000	410
3.35	140217 -6500	335			

*) Bosch Nr., see cross reference DKKC - BOSCH, microfiche HB 30, HB 31.

D15

Adjustment

Fuel injection pump (PFR-KX)

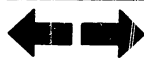

D16

Adjustment

Fuel injection pump (PFR-KX)



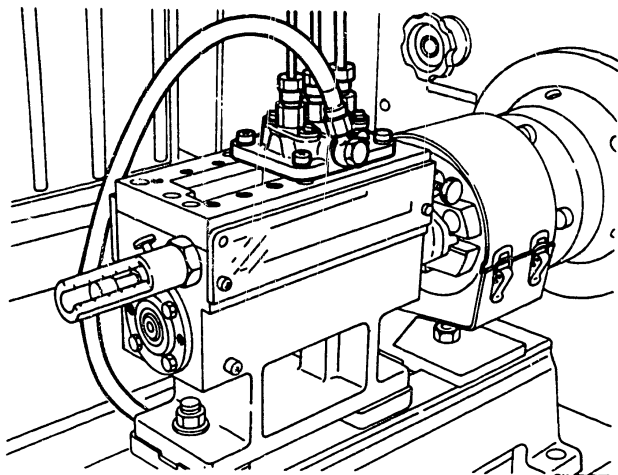

Fig. 66 Attaching the injection pipes

Injection quantity adjustment

- 1. Install the test nozzle holders on the pump test stand and connect the injection pipes (1 680 750 014) to the delivery valve holders. (Figure 66)**
- 2. Fix the control rack in the position specified in the calibration data and run the pump at the specified speed.**
- 3. Measure the injection quantity under the conditions specified in the calibration data.**

Note: Rotate the driving stand's camshaft in a clockwise direction (viewed from the drive-side).



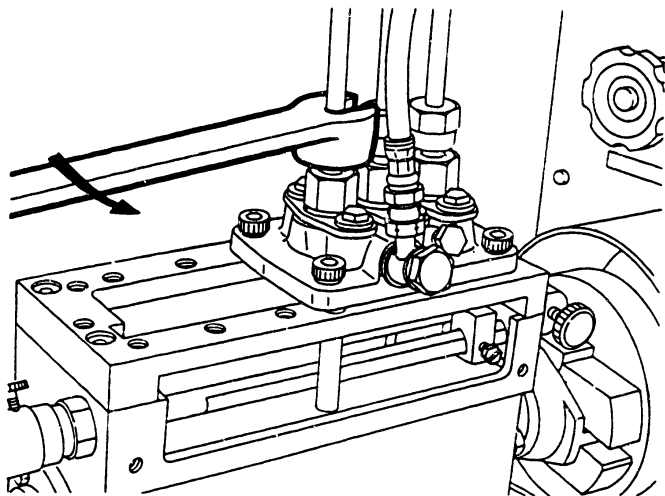

Fig. 67 Loosening the injection pipe

4. If the injection quantity is not as specified, readjust the injection pump as described following.
 - 1 Loosen the injection pipe of the cylinder being adjusted. (Figure 67)

D18

Adjustment

Fuel injection pump (PFR-KX)



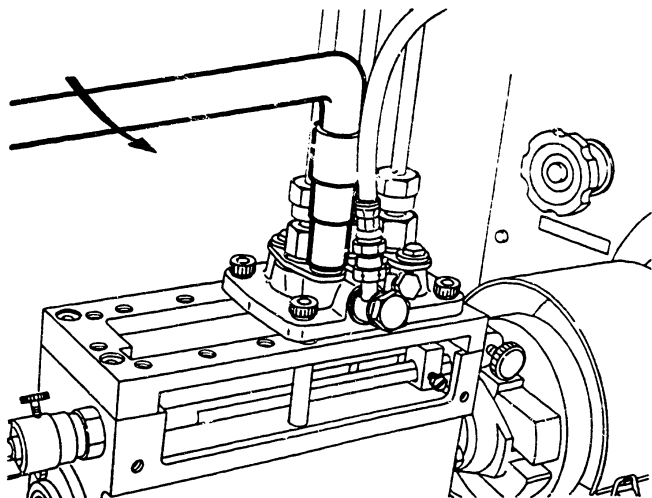

Fig. 68 Loosening the sleeve flange bolts

- 2 Using a wrench loosen the five-sided bolts (37) holding the sleeve flange (30).

D19

Adjustment

Fuel injection pump (PFR-KX)



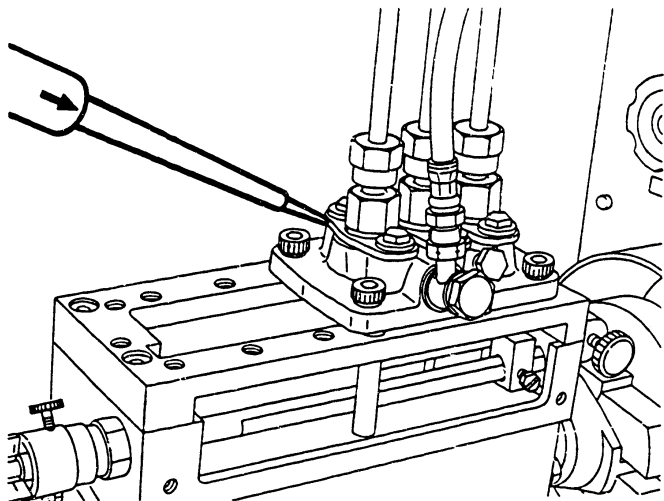

Fig. 69 Adjusting the injection quantity

- 3 While lightly tapping the sleeve flange, adjust the injection quantity. When moving the sleeve flange clockwise, as shown in Figure 69, the injection quantity is varied as indicated below (depending on the type of plunger helix).

Right hand helix : injection quantity increases

Left hand helix : injection quantity decreases

D20

Adjustment

Fuel injection pump (PFR-KX)



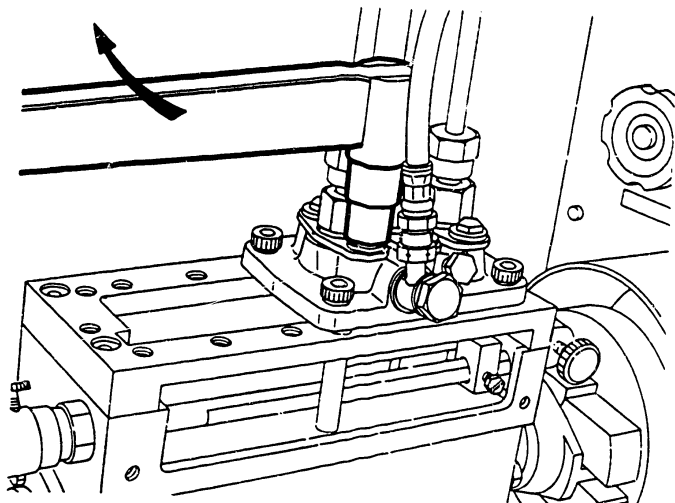

Fig. 70 Retightening the sleeve flange bolts

- 4 Tighten the left and right hand five-sided bolts to the specified torque and remeasure the injection quantity. (Figure 70)

Tightening torque : 1.8~2.3 kg-m

- 5 After adjustment check that each screw is tightened to the specified torque (refer to Figure 72).



HANDLING

The injection pump is constructed of precision components and plays an important role as the "heart" of the engine. Therefore, do not disassemble it unnecessarily. If engine functions deteriorate or the engine cannot be started, refer to the engine's work-shop manual. Remove the injection pump from the engine only when trouble is directly attributed to the injection pump.

D22

Handling

Fuel injection pump (PFR-KX)



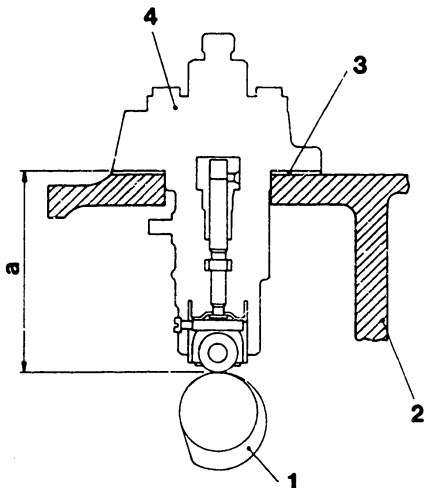

Fig. 71

- 1 = No. 1 cylinder cam
- 2 = Cylinder body
- 3 = Adjusting shim
- 4 = Injection pump

a = Distance L

Pump installation

1. Rotate the engine's injection pump drive camshaft to position the NO.1 cylinder in the bottom dead center position. (Figure 71)
2. Measure the distance (L) between the cam face and the surface of the cylinder body where the injection pump is installed. Adjust this distance using shims (supplied by the engine manufacturer) until it is as specified the following:



Pump installation (continuation)

PFR-KX type pump : $L = 76 \pm 0.05$ mm

- If L is too small, the plunger will strike and damage the plunger barrel.
- If L is too large, the tappet roller will not contact the cam when the cam is in the bottom dead center position, resulting in damage to the tappet's guide pin. Insufficient cam lift may also result, resulting in insufficient output due to a decreased injection quantity.

Pump removal

When removing the injection pump from the engine refer to the engine's workshop manual. At this time, disconnect the injection pump's control rack/governor connection after fixing the governor's control lever (engine side) in the specified position.



TROUBLESHOOTING

The following are possible diesel engine malfunctions related to PFR-KX type injection pump problems, with their causes and remedies.

Malfunctions	Causes	Remedies
Engine does not start		
1. Fuel oil does not reach fuel filter.	<ol style="list-style-type: none"> 1. Empty fuel oil tank 2. Clogged fuel oil pipe. 3. Fuel filter's suction side gauze filter is clogged. 	<p>Supply fuel oil and bleed of air.</p> <p>Clean or replace.</p> <p>Clean.</p>
2. Fuel oil reaches fuel filter but is not injected from injection pump.	<ol style="list-style-type: none"> 1. The filter element is dirty and therefore blocked. 2. The filter's overflow valve is stuck open. 3. A large amount of air remains in the filter or the injection pipe. 4. The plunger is jammed. 5. The control rack is stuck at a small injection quantity position. 6. The delivery valve is stuck. 7. Faulty delivery valve seat. 	<p>Clean or replace.</p> <p>Replace.</p> <p>Bleed of air.</p> <p>Replace.</p> <p>Repair or replace.</p> <p>Replace.</p> <p>Replace.</p>
3. Fuel injection timing is incorrect.	<ol style="list-style-type: none"> 1. Injection pump and engine are improperly connected. 2. Injection pump tappet roller is worn excessively. 3. Plate is worn excessively. 4. Plunger is worn excessively. 	<p>Repair or readjust timing.</p> <p>Replace tappet assembly.</p> <p>Replace.</p> <p>Replace.</p>

D25

Troubleshooting
Fuel injection pump (PFR-KX)

D26

Troubleshooting
Fuel injection pump (PFR-KX)



Troubleshooting (continuation)

Malfunctions	Causes	Remedies
4. The nozzle does not operate.	<ol style="list-style-type: none"> 1. Nozzle needle is stuck or does not move smoothly. 2. Nozzle seat is badly worn or damaged. 3. Nozzle opening pressure is too low. 4. The nozzle holder edge filter is clogged. 5. Injection pipe contains air. 6. Clearance between the nozzle body and the needle is too great. 7. Nozzle retaining nut is improperly tightened. 	<p>Replace.</p> <p>Replace.</p> <p>Readjust.</p> <p>Clean.</p> <p>Bleed of air.</p> <p>Replace.</p> <p>Retighten at the specified torque.</p>
Engines starts, but operates only for a limited time.	<ol style="list-style-type: none"> 1. Injection pipes leading to the pump are blocked or the filter is dirty. 2. Air or water is mixed with the fuel oil. 3. Injection pipe contains air. 4. The fuel oil tank's ventilating device is blocked. 	<p>Clean or replace.</p> <p>Bleed of air or change to high grade fuel and bleed of air.</p> <p>Bleed of air.</p> <p>Replace.</p>
The engine "knocks"	<ol style="list-style-type: none"> 1. The injection timing is too far advanced. 2. Nozzle opening pressure is too high. 3. Some injection holes are blocked (in hole-type nozzle). 4. Nozzle injection function has deteriorated. 	<p>Readjust.</p> <p>Readjust.</p> <p>Clean or replace.</p> <p>Replace.</p>



Malfunctions	Causes	Remedies
"Black smoke" and engine "knock"	<ol style="list-style-type: none"> 1. Injection timing is maladjusted. 2. Nozzle opening pressure is too low. 3. Nozzle spring is broken. 4. Nozzle injection function has deteriorated. 5. Plunger is worn. 6. Faulty delivery valve seat. 7. Fuel injection quantity is too large, and injection timing is incorrectly adjusted. 	<p>Readjust.</p> <p>Readjust.</p> <p>Replace.</p> <p>Clean or replace.</p> <p>Replace.</p> <p>Replace.</p> <p>Readjust.</p>
Unstable engine output.	<ol style="list-style-type: none"> 1. Clogged filter element results in insufficient fuel oil supply. 2. Injection pump contains air. 3. Fuel oil contains water. 4. Plunger tends to stick and does not reach its full stroke. 5. Plunger spring is broken. 6. Control rack does not move smoothly. 7. Tappet function is faulty or tappet is worn unevenly. 	<p>Clean or replace.</p> <p>Bleed of air.</p> <p>Change to high grade fuel.</p> <p>Replace.</p> <p>Replace.</p> <p>Repair or replace.</p> <p>Replace.</p>
Unstable engine output.	<ol style="list-style-type: none"> 8. Delivery valve spring is broken. 9. Faulty sealing by delivery valve gasket due to improperly secured delivery valve holder. 	<p>Replace.</p> <p>Replace gasket and tighten delivery valve holder at the specified torque.</p>



Malfunctions	Causes	Remedies
Unstable engine output.	10. Delivery valve functions incorrectly. 11. Faulty nozzle injection function. 12. Nozzle needle does not move smoothly. 13. Nozzle spring is broken. 14. The nozzle opening pressures for each cylinder differ excessively. 15. Injection timing is adjusted incorrectly.	Replace. Clean or replace. Replace. Replace. Readjust. Readjust.
Engine output is insufficient 1. Insufficient fuel injection quantity.	1. Injection pump's control rack stop position is incorrect. 2. Plunger is worn. 3. Delivery valve gasket is damaged resulting in leakage (delivery valve holder is incorrectly tightened). 4. Delivery valve seat is damaged. 5. Delivery valve spring is broken. 6. Excessive amount of fuel leaks from nozzle. 7. Some of hole-type nozzle's injection holes are clogged. 8. Delivery valve holder stopper (if installed) is broken.	Readjust. Replace. Replace. Replace. Replace. Replace. Clean or replace. Replace.

E3

Troubleshooting

Fuel injection pump (PFR-KX)



E4

Troubleshooting

Fuel injection pump (PFR-KX)



Troubleshooting (continuation)

Malfunctions	Causes	Remedies
2. Engine "knocks" due to advanced injection timing.		Readjust.
3. Engine overheats and "black smoke" is emitted due to retarded injection timing.		Readjust.
4. Nozzle injection function has deteriorated.		Clean or replace.
Engine cannot reach its maximum speed.	<ol style="list-style-type: none"> 1. Governor function is faulty. 2. Nozzle injection function has deteriorated. 	<p>Readjust or replace.</p> <p>Clean or replace.</p>
Engine's maximum speed is too high.	<ol style="list-style-type: none"> 1. Control rack does not move smoothly. 2. Plunger does not move smoothly or is stuck. 3. Governor function is faulty. 	<p>Repair or replace.</p> <p>Replace.</p> <p>Readjust or replace.</p>
Idling speed is unstable.		
<ol style="list-style-type: none"> 1. The injection pump's control rack does not move smoothly. 	<ol style="list-style-type: none"> 1. Plunger does not move smoothly or is stuck. 2. Control rack is improperly connected to the control sleeve. 3. Plunger spring does not seat correctly. 	<p>Replace.</p> <p>Repair.</p> <p>Replace.</p>

E5

Troubleshooting

Fuel injection pump (PFR-KX)



E6

Troubleshooting

Fuel injection pump (PFR-KX)

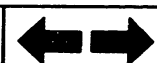

Troubleshooting (continuation)

Malfunctions	Causes	Remedies
<p>2. Fuel injection quantities of each cylinder differ excessively.</p> <p>3. Plunger is worn excessively.</p> <p>4. Plunger spring is broken.</p> <p>5. Fuel oil contains air or water.</p> <p>6. Insufficient quantity of fuel oil supplied at low speed due to clogged filter element.</p> <p>7. Nozzle injection function has deteriorated.</p>	<p>4. Clearance between plunger and lower spring seat is too small.</p> <p>5. Delivery valve holder is over-tightened.</p>	<p>Replace.</p> <p>Repair (secure delivery valve holder at specified torque.)</p> <p>Readjust.</p> <p>Replace.</p> <p>Replace.</p> <p>Bleed of air or change to high grade fuel.</p> <p>Clean or replace.</p> <p>Clean or replace.</p>

E7

Troubleshooting

Fuel injection pump (PFR-KX)



E8

Troubleshooting

Fuel injection pump (PFR-KX)



EXPLANATION OF PART NUMBERS

CODE NUMBER

1 0 4 1 3 5 - 3 0 0 0
 (1) (2) (3) (4) (5)

- (1) PFR-KX type injection pump
- (2) Plunger diameter (mm)
 - 0 : Except ϕ 5 to ϕ 8 6 : ϕ 6.5
 - 3 : ϕ 5 7 : ϕ 7
 - 4 : ϕ 5.5 8 : ϕ 7.5
 - 5 : ϕ 6 9 : ϕ 8
- (3) Number of cylinders
 - 1 : 1 cylinder
 - 2 : 2 cylinders
 - 3 : 3 cylinders
 - 4 : 4 cylinders
 - 5 : 5 cylinders
 - 6 : 6 cylinders
- (4) Specific number
- (5) Modification code

BOSCH TYPE NUMBER

N P - P F R 3 KX 6 5 / 1 N P 1
 (1) (2) (3) (4) (5) (6) (7) (8) (9)

- (1) Manufactured by Diesel Kiki Co., Ltd.
- (2) Injection pump
- (3) Without camshaft
- (4) With tappets
- (5) Number of cylinders
- (6) Size
- (7) Plunger diameter (mm) \times 10
- (8) Plunger helix
 - / 1 : Left hand helix
 - / 2 : Right hand helix
- (9) Modification code

E9

Explanation of part numbers
 Fuel injection pump (PFR-KX)



E10

Explanation of part numbers
 Fuel injection pump (PFR-KX)



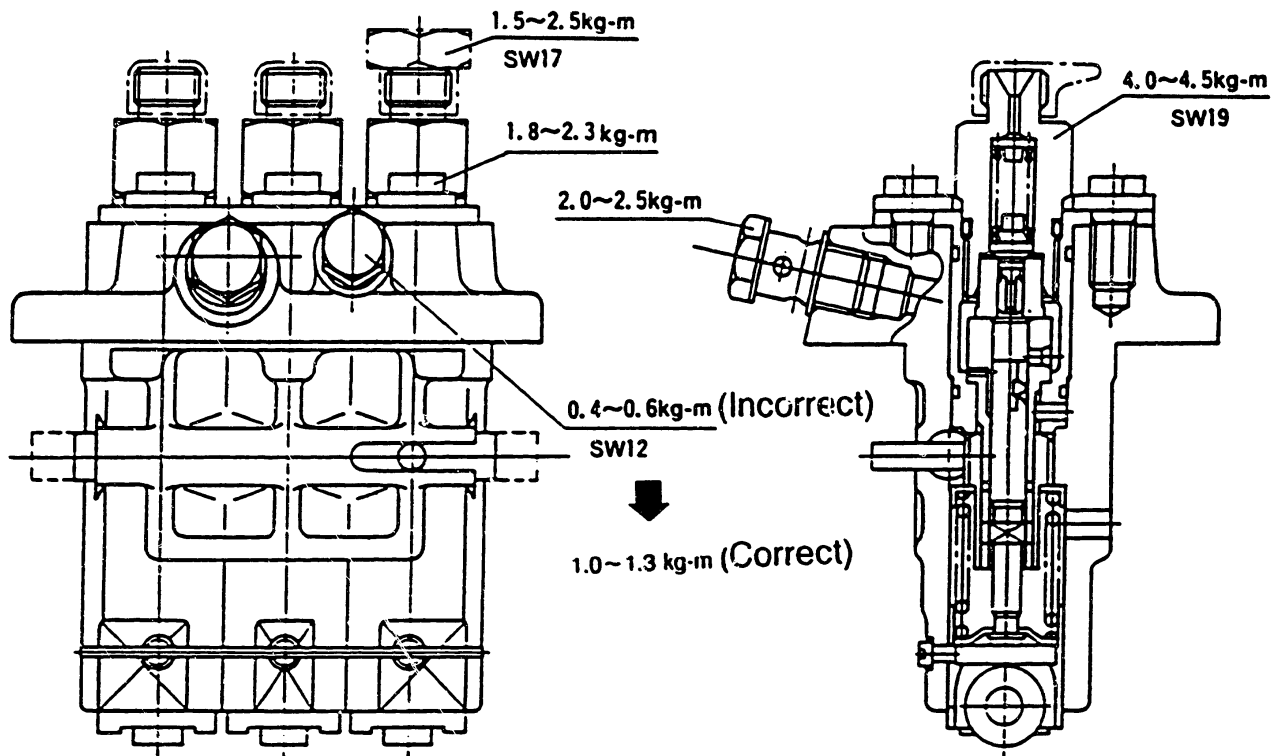

Fig. 72

TIGHTENING TORQUES

E11	Tightening torques	➔
	Fuel injection pump (PFR-KX)	

E12	Tightening torques	➔
	Fuel injection pump (PFR-KX)	

CONTENTS

	Coordinates
FEATURES	A 2
FUEL SYSTEM	A 8
CONSTRUCTION AND OPERATION	A 11
SPECIAL TOOLS	A 26
DISASSEMBLY	B 22
INSPECTION	C 13
REASSEMBLY	C 19
ADJUSTMENT	D 2
HANDLING	D 22
TROUBLESHOOTING	D 25
EXPLANATION OF PART NUMBERS	E 9
TIGHTENING TORQUES	E 11

